

# WORKSHOP 2003

Deutsch  
English  
Français  
Nederlands  
Italiano  
Español



**Rotes Garantiekarten-  
Anforderungsblatt  
beachten!**

**Read red sheet and  
order warranty card!**

**Lisez la feuille rouge  
et commandez la carte  
de garantie!**

# **marta<sup>®</sup> SL**

# **marta<sup>®</sup>**

# Inhaltsverzeichnis

1. Introduction	3
2. Safety instructions before the first ride	4
3. Safety instructions before every ride	4-5
4. Transport of the bicycle	5
5. Brake installation	6-9
6. Shorten the hose	9-11
7. Maintenance	11-13
8. Repairs	13-15
9. Bleeding and Filling	15-16
10. Trouble Shooting	17
11. The disc brake wheel	18
12. Accessories	19
13. Warranty	19
14. Spare parts exploded view	20-21



## **WARNING:**

This symbol means possible danger for your health and even life if you do not follow the instructions given resp. if the necessary safety measures are not followed.



## **ATTENTION:**

This symbol warns you of inappropriate handling that might cause heavy damage to the material and/or the environment.



## **NOTE:**

This symbol is giving you additional information about the general handling of the product or gives hints to paragraphs of this manual which have to be read carefully.

# 1. Welcome to the Brake People!



Brake lever (master cylinder)  
MAGURA Marta<sup>®</sup>

Congratulations! You have purchased a fully hydraulic MAGURA disc brake proudly „Made in Germany“. You will be enthusiastic about the awesome braking power and the very little maintenance that is necessary on our stoppers. Good to know that you are not alone, millions of users worldwide rely on them and every day we're becoming more.



Brake caliper and rotor  
MAGURA Marta<sup>®</sup>

On the fully hydraulic MAGURA disc brake system Marta and Marta SL the braking force is transmitted to the braking surface by a mineral oil column. The movement of the lever blade moves a piston, which is integrated in the brake lever (master cylinder). The piston pushes the mineral oil column through the brake hose in the direction of the brake caliper, where two pistons, on which the brake pads are fixed, are pushed out. The friction between the brake pads and the rotor is slowing down the bicycle and causes a heating of both the rotor and the brake caliper.

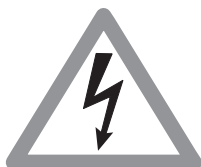

**Never touch either the rotor or the brake caliper after long braking as this may cause serious burns**

You will be pleased to find out that the MAGURA Marta disc brake offers a superior braking power even with little hand force applied, no matter what the weather conditions should be. Particularly in wet weather conditions disc brakes are much more responsive than rim brakes and transmit their enormous power shortly after activating the brake lever.

Disc brakes do not cause a wear of your rims. In case of insufficient mounting conditions they might however cause a squealing noise during braking, mainly in wet weather conditions.

**This manual contains important information about the safe installation, operation and maintenance of your MAGURA disc brake. We urge you to read it carefully, become familiar with its contents and follow our recommendations to help make your new braking experience enjoyable and trouble free.**



**All steps will be explained on the Marta model. The Marta SL is technically identical, with the exception of the SL rotor (which is compatible with Marta) and the carbon lever blades.**

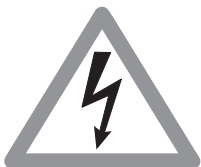

**Although the Marta disc brake system is relatively simple you should not overestimate your technical skills! We therefore advise you to leave the following works to a trained technician of a professional bike shop.**

In case of any further questions or problems we warmly recommend to visit our website [www.magura.com](http://www.magura.com) where you will always find the newest and hottest tips about all our products. Stay tuned with the Brake People! **Thank you for your confidence in our products, enjoy your ride and your new MAGURA disc stoppers!**

**Happy trails!**

## 2. Before the first ride

1. Are you already familiar with hydraulic disc brakes? Our brakes might be much more powerful than the stoppers on which you relied so far. Take your bicycle to a safe area to learn the proper braking technique and operation of your new brakes and your bike.

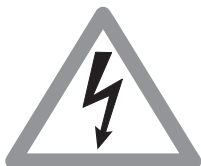

2. Check whether you activate the front brake with the brake lever, which you are used to braking on the front. If ever this is not the case you will have to train your new setup because any unintended braking might cause an accident with possible heavy bodily injury! Change the hose connection by a trained technician in case of any doubts.

*Further hints concerning the swapping of the brake hose see page 10 onwards.*

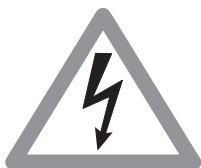

3. New brakes and new rotors or brake pads must always be run in by breaking at least 30 times from a speed of 30km/h to achieve the maximum brake power. Take your bike to a safe place to run in the brake.

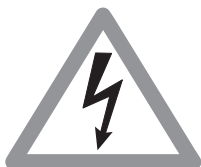

4. In case of extreme riding conditions (total weight of bike plus rider over 100kg and/or a gradient of more than 15%) always use both brakes simultaneously to brake your bike down.

5. Do not use the Marta disc brake for downhill sport or on tandems! Any misuse might cause heavy accidents with fatal injuries for you and others!

6. Are you familiar with the other components on your bike such as shifting, clipless pedals and suspension units? Always train the perfect handling of your bike in a safe area before using it in the public traffic. Consult the user's manual of your bike to learn more about this.

7. For your own safety always wear a helmet when you ride a bicycle. Make sure as well that your clothing and footwear are suitable.

## 3. Before every ride

always check carefully the following points:

1. Always make sure that the quick release skewers of your wheels and seat post are correctly mounted and closed.

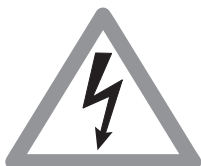

**incorrectly installed quick release skewers might cause the fixed items to get loose. Serious falls with heavy bodily injury might be the result!!**

2. Always make sure that the brake lever pressure is o.k. by pulling the lever blade and ensuring that full braking performance is achieved before the lever blade touches the handlebars. If this is not the case, pull the lever blade several times (pump) until the brake pads touch the rotor.

In case, of changing pressure points during a ride you might have air in the brake system.

See hints about filling and bleeding from on pages 15/16.

3. Always make sure that the brake system does not have any leaks by activating the lever blade, holding it and checking the hose connections and reservoir cover for eventual leaks. (Also see page 11)

4. Always protect your rotors and brake pads from oil and lubricants (e.g. by lubricating your chain). Avoid detergents and soap on the brake pads. **Contaminating the pads with oil and lubricants will cause a permanent loss of braking power. Those pads are definitely killed and cannot be saved. They have to be replaced!** Clean a contaminated rotor with dishwater or alcohol. See further hints about the brake pad change on pages 11- 13.

5. Release your brake lever and check whether your wheel moves freely and without drag. Check eventually whether the wheels are correctly mounted and if the quick release skewers are sufficiently tightened. (Also see page 9)

6. Are your tires in a good condition, and are they sufficiently pressurized? Test this with your fingers. Lift up your bike and turn the wheels of your bike. An insufficient rotation might be due to damaged tires, broken axles and/or broken spokes.

7. Pick up your bike and let it drop from a moderate height. Be careful in case of any rattling noise. Check the bearings and all screwed connections.

8. Always follow the instructions given in the owner's manual of your bicycle.

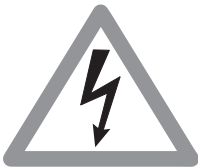

**Never use your bicycle if ever a proper function of the points mentioned above is not guaranteed. Consult a professional bike mechanic if you feel unsure. A faulty bicycle might cause serious accidents with possible fatal injuries of the rider!**

## 4. Transport of the bicycle

**In case of a disc brake equipped bicycle you should always keep in mind the following points:**

Never activate the lever blade without the brake pads in place and the wheels mounted. In case this should have happened see page 10 of this manual.

**Never throw away the transport device, which has been delivered with the brake. Always clip it between the brake pads whenever the wheel is removed (e.g. transport of the bike).**

Always carefully removed wheels. Make sure that the rotors are not damaged, deformed or contaminated with lubricants.

Do not transport the bike upside-down.

For a transport in an aircraft you can leave your brake as it is, e.g. you do not have to empty it.

## 5. Brake Installation

### 1. Tools for installation (+maintenance)

Allen key 2\*, (2,5, 3) and 5  
transport/mounting device\*  
sharp knife  
8mm open end wrench  
flat blade screw driver  
Torx T25 key\*  
(Torx T7 key)

(\* delivered with the brake)



**Always insert the allen and torx keys completely to avoid damaging the bolt heads.**

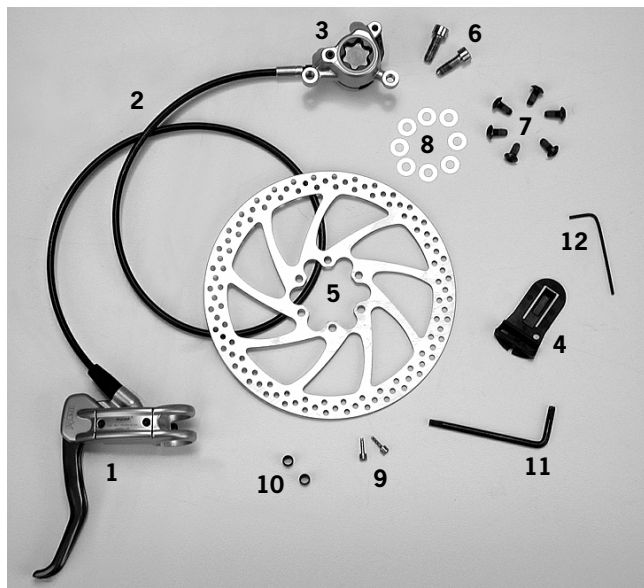

### Unpack your Marta disc brake:

1. brake lever (master cylinder) connected through the
  2. brake hose with the
  3. brake caliper with transport device (shown is International Standard version;  
**ATTENTION:** remove
  4. **YELLOW** transport device only shortly before installation of the wheel!)
  5. rotor (**diameter front and rear 160mm**)
  6. fitting bolts for caliper Allen key 5 (2 pieces)
  7. fitting bolts for rotor Torx key T25 (6 pieces)
  8. 0,2mm spacers (8 pieces)
  9. hose inserts (2 pieces)
  10. olives (2 pieces)
  11. Torx T25 key
  12. Allen key 2
- not shown:** hose fitting kit for rear brake (comes with all rear brakes)

**specifications modifying and improving this product are subject to change without prior notice.**

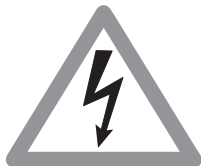

**The brake levers, calipers and hoses of the different MAGURA disc brake models are completely different and not compatible! Never mix and match parts from the different models! Any misuse might cause serious accidents!**

MAGURA manufactures these braking systems according to the valid standards and based on profound product tests. Because of the large variety of forks and frames available on the market it is impossible for MAGURA to test all possible combinations. If you mount any of our brake systems always make sure that the brakes are in conformity with the bicycle.



**Disc brake calipers can generate a lot of heat during extreme riding conditions. The resulting heat transfer from the caliper to the fork and/or frame can have a negative influence on the mechanical characteristics of both the fork and/or the frame.**

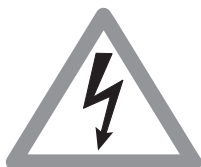

**Insufficient heat transfer from the brake caliper to the frame and the fork, caused by fork and or frame components having low heat transfer characteristics (e.g. carbon rear triangles) can cause the brake to overheat, with the possibility of a total failure of the brake system. This can cause serious personal injury to yourself and/or others.**

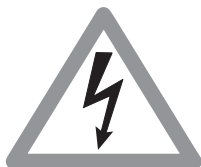

**With respect to product liability we remind all our users that any manufacturer (also: bike mechanic or end consumer!) is responsible for the correct function of the complete bicycle in this context. Improper combinations and insufficient installation might cause damage and serious accidents!**



**2. Mount the brake lever to the handlebar with a 5mm allen key. Tightening torque 4Nm/34 in.lbs**



**The MAGURA disc brake Marta is compatible with frames and forks which meet the international standard (IS) for disc brake installation. Only the front brake is available with a special Postmount caliper. Never mount the brakes with adapters or brackets from other manufacturers. All warranty will be void in case of any misuse! Use only direct mounting parts from MAGURA or the frame or fork's manufacturer!**

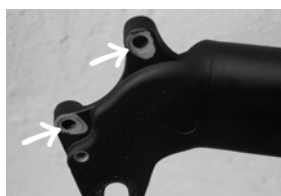

Make sure that the caliper fitting eyelets on your frame or fork are free of any paint, powder coating or burrs. (arrows). If this is not the case you should contact your dealer who is able to care for the absolutely necessary even surface with the help of the MAGURA Gnann-o-mat disc optimizer tool (also see page 9).

**ATTENTION: The treatment of suspension fork lower legs made of magnesium might be dangerous because of corrosion! Always follow the safety instructions given by the respective manufacturer! Always make sure after having treated the disc brake mounts that these are protected against corrosion by using an appropriate protective paint.**



3. Mount the caliper onto the fork or the frame. Use a 5mm allen key. **Tightening torque: 6Nm/51 in.lbs.**



4. The front brake is also available with a special caliper for the so-called Postmount, which you find on Manitou suspension forks. MAGURA does **not** offer rear brakes for the Postmount! Installation: Mount caliper with MOUNTED wheel and rotor. Do not tighten the caliper bolts yet! Squeeze the lever blade and keep it. Tighten now the bolts. **Tightening torque: 6Nm/51 in.lbs.**



5. Very often frames are not well aligned to ensure a drag free mounting of the brakes. You may have to use then the 0,2mm spacers, which you should install as shown by the arrows between fitting eyelets and brake caliper. (See also the 2 caliper sketches on page 9).

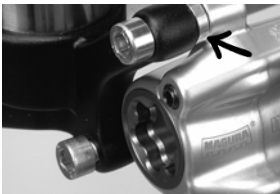

6. If you use a thru-axle hub you **must** use thicker 3mm spacers. These are either available separately (code: 0720 829) or come supplied with the MAGURA Gustav M thru-axle hub. If necessary you might have to use here as well additional 0,2mm spacers for a clean and drag free positioning of the caliper.



8. Mount the rotor with the 6 Torx T25 bolts onto the hub. Watch out for the correct rotation direction of the rotor (laser arrow). Use only new original bolts or thread lock if you use old bolts. **Tighten the bolts in a crossed pattern! Tightening torque: 4Nm/34 in.lbs.**



9. Remove the transport device shortly before installing the wheel.



The transport device prevents the brake pads from being pushed out too far by unintended lever squeeze. It is impossible then to install the wheel with the rotor. So never throw away the transport device! Keep it and always clip it between the brake pads when the wheel is removed.

Install the wheel by positioning the rotor between the brake pads and fixing the wheel in the dropouts. Close the quick release of your wheel **which you should mount on the opposite side of the brake caliper** and tighten it sufficiently. As to thru-axle hubs or wheels consult the manual of the respective fork manufacturer.

Squeeze the lever blade several times (pump) to push the pads to their proper position until the lever feel becomes very firm.

**10.** Correctly mounted disc brake wheel.



The rotor has to run directly between the brake pads for a drag free function). If ever this is not the case re-position the caliper with the 0,2mm spacers.

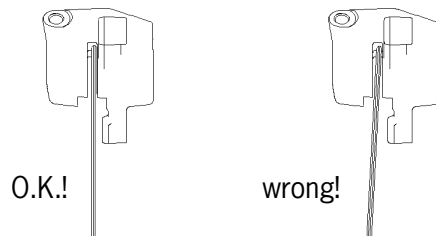

**Do not worry when you hear friction between rotor and pads. A slight drag is normal on disc brakes with automatic pad wear adjustment during the break-in period. This drag will disappear after a while. The reason for this is that the brake pads find their optimum working position towards the rotor, only after a slight wear during the break-in period. Slight drag might also happen after a brake pad change or in case of an incorrectly installed wheel.**

In case of a **constantly dragging** disc brake causing noise your frame or fork is badly aligned. In such a case you should contact your dealer who can care with the MAGURA Gnann-o-mat disc optimizer for a totally even surface of the disc brake mounts. These are absolutely necessary for a drag free function of your brake.

**New brakes and/or new rotors or brake pads must always be run in by breaking at least 30 times from a speed of 30km/h to achieve the maximum brake power. Take your bike to a safe place to run in the brake.**

**Reach adjust is done with a 2,5 mm Allen key.** Turning key clockwise: lever blade moves away from the handlebar, turning counterclockwise: blade moves to the handlebar.



## 6. Shorten the hose

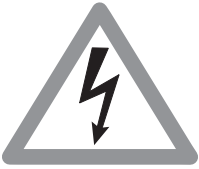

**Marta is a high-pressure system and comes with a reinforced hose, the „MAGURA Disc Tube“ wearing also this imprint. The Disc Tube needs an additional insert for a proper fitting. Never mix and match either the hoses or other parts from the other MAGURA disc brake models. Any misuse might cause serious accidents!**

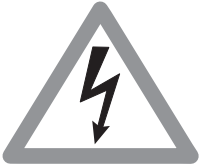

**Never touch either the rotor or the brake caliper after long braking as this may cause serious burns.**

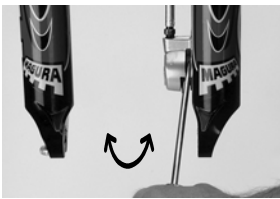

**1.** Remove the wheel so that you have free access to the brake caliper. Push both brake pads back by putting the transport device or a flat blade screwdriver into the gap. Move the screwdriver **slowly** back and forth until both caliper pistons are fully retracted and flush with caliper body.



**Never push back the pistons without the brake pads mounted! Open the brake system only after having pushed back fully the brake pads.**



**2.** Loosen the brake lever clamping screw with a 5mm allen key. Turn the brake lever and ensure that the reservoir is horizontal.



**3.** Slide the hose protection. Unscrew the sleeve nut on the brake lever with an 8mm open-end wrench and pull the hose out **carefully**. **Hold the hose carefully to avoid any loss of oil! Do not squeeze the lever blade with the system open!**



**4.** Put the hose on a workbench and shorten it with a sharp knife. The best tool is the MAGURA cutter (code 0321 233). **Do not use saws or pliers!** If your frame is not equipped for routing hydraulic lines you should now mount the hose fitting kit for your rear brake according to the instructions that are included in the kit.



**Hold the hose carefully so that it cannot snap away (arrow)! Cut the hose squarely! The sleeve nut can be re-used. The olive and the insert cannot be re-used and must be replaced!**



**5.** Press manually a **new** insert into the hose until it is **fully seated**. Clamp the hose into the groove of the mounting device as shown...



**6.** ...or clamp the mounting device as shown into a vice and hammer the insert **carefully** into the hose. If your frame is not equipped for routing hydraulic hoses you should now mount the hose fitting kit for your rear brake according to the instructions that are included in the kit.



**7.** Slide on the sleeve nut and a **new** olive onto the hose. Push the hose with the sleeve nut and the new olive **fully** into the brake lever and tighten the sleeve nut with an 8mm open-end wrench. **Tightening torque: 4Nm/34 in.lbs.**



**8.** Always check for correct installation by pulling on the hose. Make sure that the system has no leaks. Squeeze the lever blade, hold pressure and check hose connections and the reservoir cover for eventual leaks. Squeeze the lever blade several times (pump) to push the pads to their proper position until the lever feel becomes very firm. If you cannot realize this, bleed the brake (see page 15 onwards).

## 7. Maintenance

**Brake Oil:** MAGURA disc brakes use as transmission medium low viscosity mineral oil, the biodegradable MAGURA BLOOD. Contrary to DOT brake liquid the MAGURA ROYAL BLOOD does not irritate human skin or strip the paint of your frame. Moreover it does not absorb water like DOT and does not have to be changed regularly. What sounds unbelievable is a fact: you can use your brakes over years without having to touch them (except brake pad check and change!)

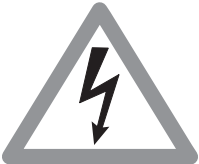

**Always make sure that the brake system does not have any leaks by activating the lever blade, holding it and checking the hose connections and reservoir cover for eventual leaks. Consult a trained technician in case of leaks. Leaks cause poor braking performance with possible serious accidents!**

*As to hints about repairs of the hose see page 14 onwards..*

### Brake pads: wear, control and replacement

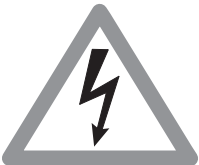

**Brake pad wear:** The brake pads are subject to wear due to friction between rotor and pads. The Marta disc brake features a fully automatic pad wear adjustment. Regularly check the thickness of your brake pads and replace them, if necessary!

### Control and replacement of the brake pads

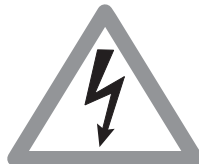

**Never touch either the rotor or the brake caliper after long braking as this may cause serious burns.**

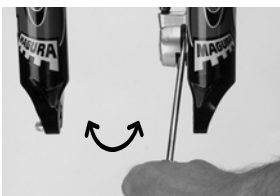

**1.** Remove the wheel so that you have free access to the brake caliper. Push both brake pads back by putting the transport device or a flat blade screwdriver into the gap. Move the screwdriver **slowly** back and forth until both caliper pistons are fully retracted and flush with caliper body.



**Never push back the pistons without the brake pads mounted!**



**2.** Remove the brake pad fitting screw with a 2mm allen key.



**3.** Pull out the brake pads. Clean the pads with a dry rag that is free of oil and grease.



**Never squeeze the lever blade without the brake pads in place and the wheel mounted! If this happened by accident push back the pistons with mounted brake pads by using the transport device or a flat blade screwdriver.**



**4. Minimum thickness of a brake pad including the holder is 2,5mm. Use only genuine MAGURA brake pads!!**



**Tip: check the pad wear with the groove of the YELLOW transport device. Pad does NOT fit to the groove (picture): o.k.! Pad does fit to the groove: change the pads!**

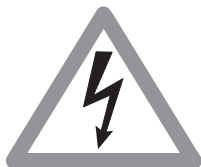

**Use only genuine MAGURA brake pads! MAGURA cannot guarantee a correct function of the brake if you use brake pads from other manufacturers, which were not tested. Using other pads might cause poor braking and cause heavy bodily injury! All warranty claims will be void in case of misuse!**

**5. Clean on the occasion of the brake pad change the brake body with a clean rag.**



**6. Mount the new brake pads. Make sure that the friction side of the new brake pads points towards the rotor. Tightening torque of the fitting screw: 1Nm/9 in.lbs. Check after installation the correct fitting of the pads by pulling them.**

**7. Check, whether the pistons are fully pushed back and whether the pads are flush with the caliper body. Push the brake pads back with the transport device or a flat blade screwdriver as described on page 12. Re-install the wheel and check for a correctly tightened quick release skewer of the wheel **that should be mounted on the opposite side of the caliper.****

**8. Squeeze the lever blade several times (pump) to push the pads to their proper position until the lever feel becomes very firm.**

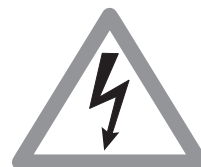

**New brakes and/or new rotors or brake pads must always be run in by braking at least 30 times from a speed of 30km/h to achieve the maximum brake power. Take your bike to a safe place to run in the brake. Never contaminate brake pads with oil or grease this causing permanent loss of brake power! Contaminated pads are definitely killed and must be replaced!**

## 8. Repairs



Disc brake service kit (code: 0721 294)

Don't panic if the hose snaps! With the disc brake service kit and a separately available spare hose (see spare parts pages 21/22), this can be repaired easily.

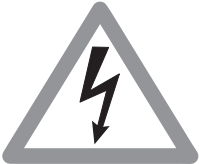

**The Marta is a high-pressure system and comes with a reinforced hose, the „MAGURA Disc Tube“ wearing also this imprint. The Disc Tube needs an additional insert for a proper fitting. Never mix and match either the hoses or other parts from the other MAGURA disc brake models! Any misuse might cause serious accidents!**

**1.** Remove the damaged hose from both the brake lever and the caliper. Cut off the barbed adapter (caliper connection) with a sharp knife. Slide both the sleeve nut and hose protector on the other side. All mentioned parts can be re-used. Throw away the damaged hose.



**2. Prepare a new hose:** Use only the reinforced „MAGURA Disc Tube“ hose! One end this hose comes with a pressed fitting, which has to be screwed into the caliper as described above. **Tightening torque: 6 Nm/51 in.lbs.**



**Never shorten this hose at the end with the pressed fitting! You could no longer use the hose then.**



**3.** Tighten the prepared end of the new hose onto the caliper. **Tightening torque: 6 Nm/51 in.lbs.**

**4.** Mount the brake hose as described in chapter 6.



**After the installation of a new hose you will always have to refill the brake. The following chapter 9 describes how the filling has to be done.**



## 9. Filling and bleeding a brake



**Brake oil:** MAGURA disc brakes use as transmission medium low viscosity mineral oil, the biodegradable MAGURA ROYAL BLOOD. Contrary to DOT brake liquid the MAGURA ROYAL BLOOD does not irritate human skin or strip the paint of your frame. Moreover it does not absorb water like DOT and does not have to be changed regularly. What sounds unbelievable is a fact: you can use your brakes over years without having to touch them (except brake pad change!)



1. Loosen slightly the clamping screw of the brake lever with a 5mm allen key and turn the brake lever so that the reservoir is positioned horizontal. Slightly tighten the clamp screw in that position.



2. For filling and bleeding a MAGURA disc brake you will need the disc brake service kit (Code: 0721 294) including all necessary tools.

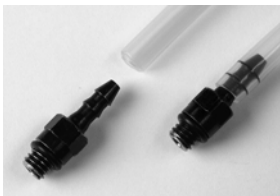

3. Prepare the transparent filler tube by pushing in by hand the M6 barbed fitting on which you have mounted an O-ring before. Put the other end of the filler tube on the syringe and fill the syringe **completely** with MAGURA ROYAL BLOOD mineral oil. Fill the syringe completely and make sure that **there are no air bubbles inside**. Turn the syringe eventually to push out air bubbles.



4. Remove the brake pads as described on page 12 and slide the YELLOW transport device as shown **with its THICK END** between the caliper pistons. Squeeze slightly the lever blade (pump) to tighten the transport device. **Only use the YELLOW transport device for this procedure, the formerly used black one is not suitable for this work!**



5. Fix the caliper so that the hose connection is at the highest point of the caliper (hose has to be positioned vertically!). It might be necessary that you have to unscrew the lower caliper fitting bolt and to fix the caliper to realize this properly (e.g. on rearbrakes!) Unscrew bleeding screw with a 3mm Allen key. Screw in the prepared syringe and tighten it by hand.



**Place now a rag, which has to be free of oil or lubricants around the reservoir and, more important, around the brake caliper. Care for a clean working environment! No dirt or particles may come into the brake system!**



**6.** Unscrew the Torx T7 reservoir cover screws and remove the cover with the membrane sitting below. Begin to **slowly** press the oil contents of the filling syringe through the system until no further air bubbles can be seen

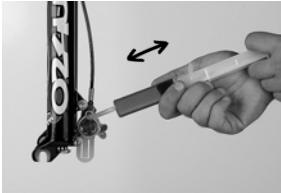

**7.** Press the MAGURA ROYAL BLOOD oil through the system. Use a second syringe to suck any overflowing oil at the reservoir. Then pull the filler syringe to suck oil back. Repeat procedure 3-4 times and actuate CAREFULLY the lever blade simultaneously. **Make sure that there is always enough oil in the reservoir when you suck the oil with the filling syringe.**



**8.** Use the second syringe to suck any overflowing oil. The rag around the brake lever and the caliper prevents overflowing oil from dropping down and contaminating and killing the brake pads. Push **the complete contents** of the filling syringe through the system.

**9.** The reservoir has to be full to the top before replacing the membrane and the cover.



**10.** Replace the cover with the membrane onto the reservoir. Oil will spill during this procedure therefore do not forget to place a rag around the brake lever! Tighten the cover screw until the cover is flush with the reservoir. **Use only the original Torx T7 screws! Any other screw will lead to leaks, damages and failure of the whole system! Tightening torque 0,6Nm/5 in.lbs**



**11.** Remove the syringe and screw in the 3mm allen bleeding screw. **Tightening torque: 2,5Nm/22 in.lbs.** Re-position, if necessary, the brake caliper (**tightening torque 6Nm/51 in. lbs.**). Remove the transport device, re-install the brake pads and the wheel.

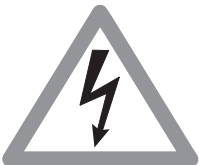

**Always pull the lever blade several times (pump) until the brake pads touch the rotor.**

**Always check for correct installation by activating the lever blade and checking for eventual leaks.**

**Never contaminate brake pads with oil or grease this causing permanent loss of brake power! Contaminated pads are definitely dead and MUST be replaced! A contaminated rotor can be cleaned with warm dishwater or alcohol.**

## 10. The disc brake wheel

### The XC disc brake wheel

There already exists enough literature concerning wheels, so just a few tips how a well-built X-country disc brake wheel has to be.



Use spokes with a diameter of 2mm (arc)/1,8mm which you cross three times.

#### **No radial lacing with disc brake wheels!**

Head-inside-spokes (=arc-outside-spokes have to be pulled, i.e. these spokes point forward on the front wheel; on the back wheel these spokes point forward on the rotor side and backwards on the drive side. All spokes have to be stressed equally and high.

**Mount the quick release of the wheel on the opposite side of the caliper!**

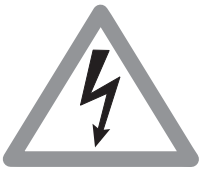

**Never use ultra lightweight quick releases with titanium or aluminum axles for your wheel sets in combination with a disc brake. You will not be in a position to realize the necessary tightening torque!**

# 11. Trouble Shooting

problem	reason	solution
not enough brake power no pressure point	brake was not run it	break in the brake (page4)
	oil/lubricants on rotor and/or pads	clean the rotor with warm dishwater or alcohol replace contaminated brake pads
	air in the system	bleeding the brake (page15)
	leaking systems	Check hose connections and hose for leaks; replace hose if necessary (pages 14/15)
Squealing brake	badly aligned frame	align brake caliper with 0,2mm spacers (page9)
	Paint/powder coating on fitting eyelets	remove any paint or powder coating and care for an even contact surface without burrs. (page7)
	Wheel q/r skewer insuffi- ciently tightened	Increase tightening of q/r skewer and <b>mount it on opposite side of caliper.</b>
	Insufficiently tightened wheel spokes	check for an evenly spoked wheel with high spoke tension
contaminated brake pads	carelessness	brake pads must be changed
contaminated rotor	carelessness	clean rotor with dish water or alcohol
wheel cannot be mounted	Lever blade was pulled with removed wheel	Push back the brake pads with transport device or a flat blade screwdriver. (page12)
rattling noise and rough deceleration	brake pads worn, holder of pads is wearing the rotor	brake pad change (page 12)
leaking hose or brake	accident, incorrect installation	change hose or defective brake lever or caliper (page 14)



You will find further tips on our website [www.magura.com](http://www.magura.com) in the FAQ section!! Stay tuned.

## 12. accessories



### **MAGURA disc brake service kit, code: 0721 294**

contains everything that you need for bleeding and repairing a brake. ATTENTION: the kit does NOT include a spare hose!



### **MAGURA braided hose for all MAGURA disc brakes**

**easily shortened** with a cable cutter, 1700mm

0° fitting: code 0721 203

**Watch out for the genuine hose with yellow MAGURA marker!!**



### **Use only genuine MAGURA brake pads!**

brake pads Marta Performance Type 5.1: code 0721 340

series pad for maximum brake power

brake pads Marta Endurance Type 5.2: code 0721 672

with optimized longevity

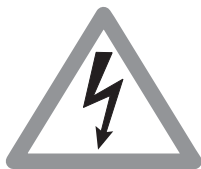

**Use only genuine MAGURA accessories! Any parts manufactured by other manufacturers like lever blades, hoses or brake pads have not been tested and approved by MAGURA and consequently nothing can be said about their short and long-term function. Never use those parts! All warranty and product liability claims will be void in case of misuse!**

**Never change the paint, the finish or the consistence of your brake. This might cause total failure of the whole system with possible heavy bodily injury!**

## 13. Warranty

MAGURA is giving a **5 years leak proof warranty** on brake levers (master cylinder) and brake calipers. Watch out for the red order form of the warranty card in this manual and order your warranty certificate!

**This warranty is void when damage to the brake has occurred from the following:**

abuse

mixing and matching the brake with parts from other manufacturers

damage of the exterior finish caused by improper use

any attempt to disassemble the whole brake

modifications

non-factory changes or improper service

shipping damages or loss (purchase of full value insurance is recommended).

# spare parts 2003/max. tightening torques

Torx T7 key  
0720 847

**Marta SL (silver):**  
left: 0721 673  
right: 0721 674

**Marta (black):**  
left: 0721 675  
right: 0721 676

**SL-rotor**  
Ø 160mm  
**only 6 holes**  
**version available!**  
0721 640

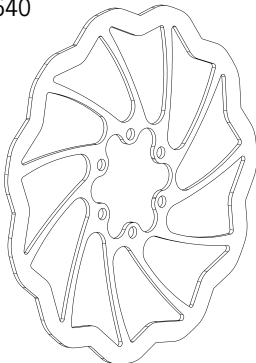

**Marta SL (silver):**  
VR: 0721 691  
HR: 0721 692  
**International Standard**

**Marta (black):**  
VR: 0721 677  
HR: 0721 678  
**International Standard**

0721 314

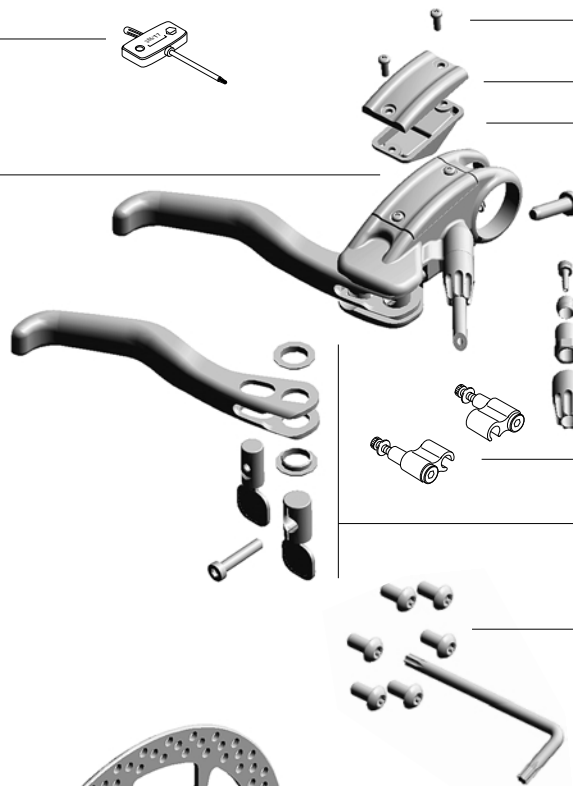

10x: 0721 000 **0,6 Nm/5 in.lbs.**

0721 285 (silver)  
0721 575 (black)  
0721 286

10x: 0720 918 **4Nm/34 in.lbs.**

10x: 0720 825  
20x: 0720 916  
10x: 0720 446  
10x: 0720 405

2x: 0721 214

**Marta SL:**  
2x: 0721 642

**Marta:**  
2x: 0721 388

6x: 0721 057 **4 Nm/34 in.lbs.**

Torx T25 key: 0721 204

**standard rotor**  
Ø 160mm  
**ONLY 6 holes version available!**  
0721 620

standard hose 0°  
1600 mm: 0720 826 **6Nm/51 in.lbs.**  
2500 mm: 0720 827 **6Nm/51 in.lbs.**  
braided hose 0°  
1700 mm: 0721 203 **6Nm/51 in.lbs.**

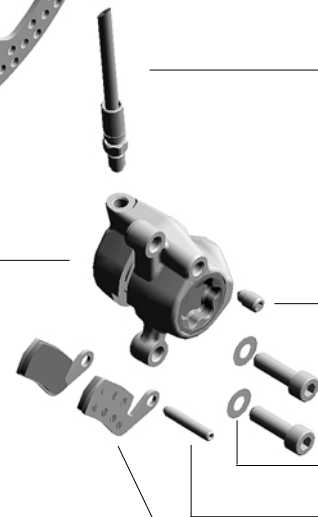

10x: 0720 931 **2,5Nm/22 in.lbs.**

2x: 0721 057 **6Nm/51 in.lbs.**

20x: 0720 917 (0,2 mm spacer)

10x: 0720 828 **1Nm/9 in.lbs.**

2x: 0721 340  
Type 5.1 Performance  
2x: 0721 672  
Type 5.2 Endurance

**Marta SL (silver)**  
0721 693  
**Marta (black)**  
0721 679

**Manitou Postmount 74**

**hubs**

Pro:

front/silver	0721 146
front/black	0721 153
rear/silver	0721 147
rear/black	0721 154

Comp:

front/silver	0721 148
front/black	0721 155
rear/silver	0721 149
rear/black	0721 156

Fun:

front/black	0721 355
rear/black	0721 357

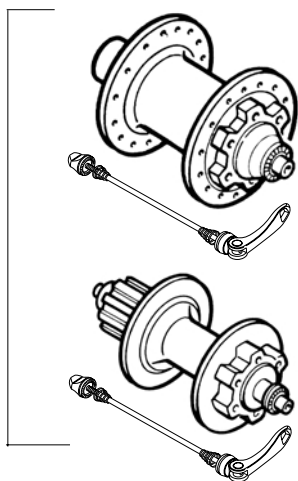



**MAGURA Bike Parts GmbH & Co.**  
Heinrich Kahn Straße 24  
D-89150 Laichingen  
phone ++49-(0)7333/9626-0  
fax ++49-(0)7333/9626-17  
info@magura-bikeparts.de

**Hotline/Helpdesk:**  
phone ++49-(0)7125/153-180  
daily 9-12h and 13-16h CET  
fax ++49-(0)7125/153-184  
service@magura.de

**MAGURA Partners and Service  
Centers Worldwide**

**Andorra** Esports Jorma  
phone 376-844133  
fax 376-843022  
jorma@correu.andornet.ad

**Argentina** Freier S.r.l.  
phone 4442-3108  
fax 4442-1756  
esteban@freier.com.ar

**Australia** TMO Sports  
phone 02-9695-7744  
fax 02-9695-7844  
service@velovita.com.au

**Austria** Funbike  
phone 0662-6362450  
fax 0662-6362455  
funbike@funbike.at

**Belgium** Transmission  
phone 010-244646  
fax 010-244777  
info@transmission.be

**Canada** MAGURA USA  
phone 618-3952200  
fax 618-3954711  
magura@magura.com

**Czech Republic**  
Vanek Praha  
phone 0312-698016  
fax 0312-698025  
vanek.praha@mbox.vol.cz  
Kubecka  
phone 0653-213549  
fax 0653-213549  
velo@idp.cz

**Chile** Armin Fiebig Import  
phone 09-8707652  
fax 56 2 2312910  
fiebig@entelchile.net

**Denmark** Borandia APS  
phone 47-107172  
fax 47-107066  
borandia@borandia.dk

**Finland** Best Brakes Ky  
phone 050-591 5863  
fax 019-318557  
info@bestbrakes.inet.fi

**France** MAGURA Service-Center France  
(seulement SAV via détaillants!)  
phone 03-85949021  
fax 03-85949022  
sav\_france@magura.de  
Cycles Lapiere  
phone 03-80525186  
fax 03-80520851  
henri.boissel@cycles-lapierre.fr  
Maillon  
phone 05-56386300  
fax 05-56386301  
maillon.sarl@wanadoo.fr

**Great Britain**  
MAGURA Service-Center UK  
(only service for products sent  
back by retailers!)  
phone: 01530-837195  
fax: 01530-811286  
service\_uk@magura.de  
Raleigh Parts & Accessories  
phone 0115-9855706  
fax 0115-9282044  
p&customersupport  
@raleigh-ind.com  
Venhill engineering  
phone 01306-885111  
fax 01306-740535  
info@venhill.co.uk  
Jim Walker Co.  
phone 01825-762400  
fax 01825-761845  
jim@walker.zee-web.co.uk

**Greece** Nikos Maniatopoulos  
phone 061-993045  
fax 061-990424  
idealsman@hol.gr

**Hong Kong**  
Chung Yung Cycle  
phone 02670-3639  
fax 02679-5602  
cycc168@hkstar.com

**Hungary** Mali Bicycle Technology  
phone 01-4207563  
fax 01-4205321  
mali@mali.hu

**Ireland** Beara Bike Trading  
phone 064-89134  
fax 064-41334  
wschmidt@indigo.ie

**Israel** Hobby's Cycle Systems  
phone 972-52-429905  
fax 972-3-5754529  
yossi@hobbys.com

**Italy** Weinert  
phone 0421-81217  
fax 0421-83680  
weinert@iol.it

**Japan** MC International  
phone 06-5360901  
fax 06-5360907  
mcinter@mx1.alpha-web.ne.jp

**Korea** Park's MTB  
phone 02-5122412  
fax 02-5122423  
parksmtb@hanmail.net

**Luxemburg** Transmission  
phone 0032-10-244646  
fax 0032-10-244777  
info@transmission.be

**Netherlands** NZ Parts  
phone 010-2340468  
fax 010-2340824  
nzparts@worldonline.nl

**New Zealand** Ground Zero  
phone 03-5478386  
fax 03-5478388  
info@groundzero.co.nz  
**Norway** Botolfsen  
phone 022-630610  
fax 022-970662  
info@botolfsen.no

**Portugal** LPL-Artigos Desportivos  
phone 021-4835354  
fax 021-4835362  
lpl@netcabo.pt

**Russia** Diokl  
phone 095-43402346  
fax 095-4340482  
diokl@glasnet.ru

**Singapore** The Bike Rendezvous  
phone 65-7876587  
fax 65-7876571  
magurasin@pacific.net.sg

**Slowenia** Factory Store  
phone 06-3481705  
fax 06-3481705  
factorystore@siol.net

**South Africa** Cycles Africa  
phone 011-678-1548  
fax 011-678-1548  
cunning@mweb.co.za

**Spain** SAT MAGURA: Bicisport  
Sólo para reparaciones y servicio!  
phone: 93 3404480  
fax: 93 3404480  
Bicicletas Monty  
phone 93-6667111  
fax 93-6667112  
monty@monty.es

Casa Masferrer  
phone 93-8463444  
fax 93-8465355  
cmcenter@casamasferrer.com  
Comet  
phone 943-331393  
fax 943-551407  
comet@comet.es  
Representaciones Spinola & Perez  
phone 619-702946  
fax 93-2317731  
c.perez@es.inter.net

**Sweden** Jaguarverken AB  
phone 060-669800  
fax 060-669809  
info@jaguarverken.se

**Switzerland** Intercycle  
phone 041-9266511  
fax 041-9266355  
info@intercycle.com  
Amsler & Co.  
phone 052-6473636  
fax 052-6473637  
info@amsler.ch  
**Taiwan** MAGURA ASIA Inc.  
phone 04-3239222  
fax 04-3239322  
garyyang@magura.com.tw

**USA** MAGURA USA  
phone 6183952200  
fax 6183954711  
magura@magura.com  
www.magura.com