

1

Race Installation
 Einbau des Steuersatzringes
 Instalación del anillo de rodadura
 Installation du jeu de direction
 Montaggio dell'anello della testa
 Installatie van loopring
 Instalação do canaleta
 レースの取り付け

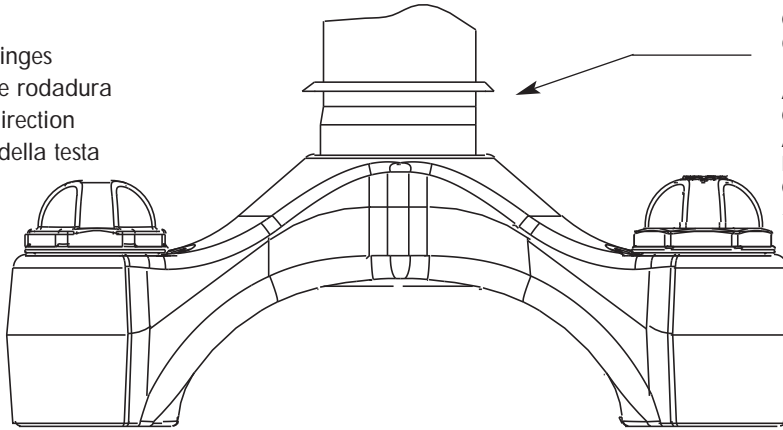

CROWN RACE
 GABELBRÜCKEN-
 STEUERSATZRING
 ANILLO DE RODADURA
 CONE DE JEU DE DIRECTION
 ANELLO DELLA TESTA
 KROONLOOPRING
 CANALETE DA COROA
 クラウン・レース

2

Tire clearance
 Reifenabstand
 Espacio libre de la cubierta
 Distance arceau/pneu
 Spazio libero del pneumatico
 Bandspeling
 Folga do pneu
 タイヤクリアランス

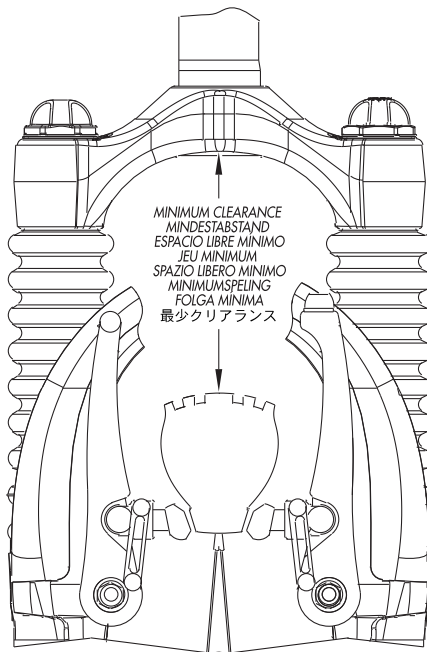

FORK MODEL GABELMODELL MODELO DE HORQUILLA MODELE DE FOURCHE MODELLO DI FORCELLA VORKMODEL MODELO DO GARFO フォーク・モデル	MINIMUM CLEARANCE MINDESTABSTAND ESPACIO LIBRE MÍNIMO JEU MINIMUM SPAZIO LIBERO MINIMO MINIMUMSPELING FOLGA MÍNIMA 最少クリアランス
MAGNUM & MAGNUM R 76 mm travel forks	3.1" (78.7 mm)
MAGNUM und MAGNUM R Gabel mit 76 mm Auslenkung	78,7 mm
Horquillas MAGNUM y MAGNUM R con recorrido de 76 mm	78,7 mm
Fourches MAGNUM et MAGNUM R ayant une course de 76 mm	78,7 mm
Forcelle MAGNUM e MAGNUM R con corsa da 76 mm	78,7 mm
MAGNUM & MAGNUM R loop van 76 mm	78,7 mm
MAGNUM e MAGNUM R curso de 76 mm	78,7 mm
マグナムとマグナム R 76 mm 動程	78.7 mm

3

Grease port
 Schmieröffnung
 Orificio de engrasado
 Graisseur
 Apertura per l'ingrassaggio
 Smeergat
 Orificio de lubrificação
 グリース・ポート

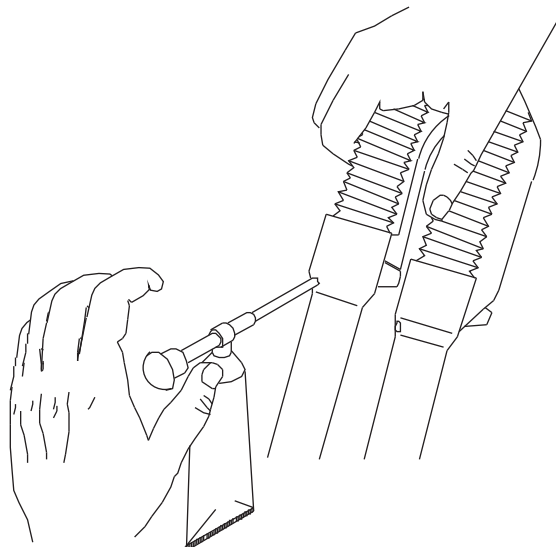

4

Oil level
Ölstand
Nivel del aceite
Niveau d'huile
Livello dell'olio
Oliepeil
Nível do óleo
オイルの量

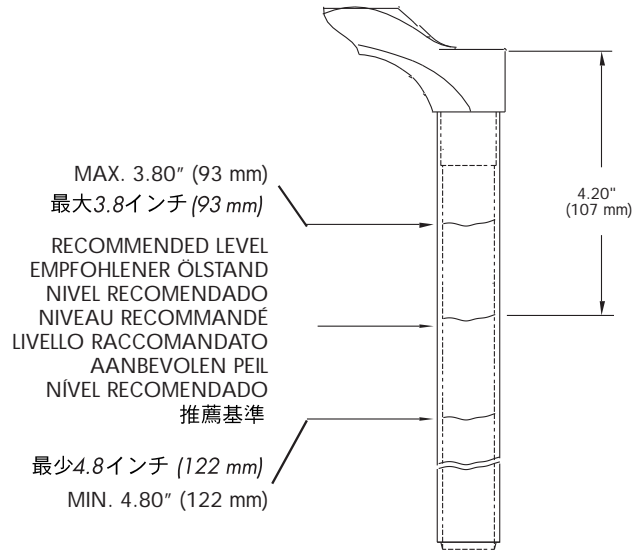

5

Fine tuning compression spring
Feinabstimmung der Druckfeder
Ajustes de precisión al resorte de compresión
Réglages fins des ressorts de compression
Messa a punto della molla di compressione
Fijnafstelling van drukveer
Mola de compressão de ajuste preciso
圧縮スプリングの微調整

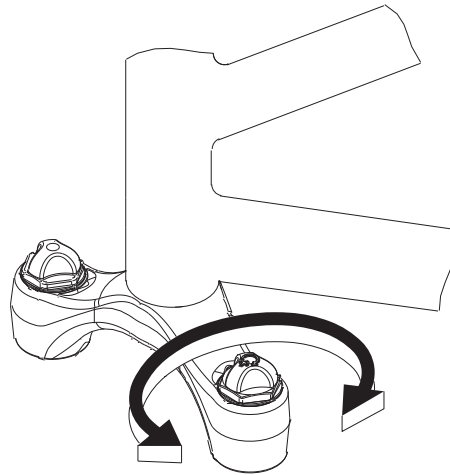

ROTATE
DREHEN
GIRAR
TOURNER
RUOTARE
DRAAIEN
GIRAR
回わず

AMERICAN MADE MANITOU SUSPENSION

CONGRATULATIONS ON CHOOSING A 2001 MANITOU MAGNUM BUILT IN THE USA. SOME WORDS ON YOUR NEW MAGNUM BEFORE WE BEGIN. THE 2001 MAGNUM FORKS USE MANITOU'S COIL/MCU SYSTEM. THE MAGNUM R USES MANITOU'S TPC SPORT PATENTED DAMPING SYSTEM THAT SURPASSES ALL OTHER TYPES OF OIL DAMPED SYSTEMS IN PERFORMANCE AND DURABILITY. MAGNUM FORKS ALSO USE MANITOU'S QUICK AND EASY MICROLUBE SYSTEM, WHICH ALLOWS YOU TO LUBRICATE THE FORK VIA AN EXTERNAL FITTING ON THE BACK OF THE FORK. ALL MANITOU FORKS COME EQUIPPED WITH 74MM POST-STYLE DISC BRAKE MOUNTS.

This Magnum fork is fully assembled and ready to be installed onto your bicycle. It comes equipped with a 1 1/8-inch threadless steerer tube, is available with a V-brake-style hangerless arch, or there's an optional attachable cable hanger which is available through your dealer.

2001 MAGNUM FORK LINE

MAGNUM 76MM TRAVEL/COIL-MCU SPRINGS/SINGLE CROWN
MAGNUM R 76MM TRAVEL/COIL-MCU SPRINGS/TPC SPORT DAMPING/ SINGLE CROWN

One last note. If you lose this manual, or want to take a look at the Magnum Service Manual or MRD Tuning Manual, head straight for the web at www.answerproducts.com or call (661) 257-4411 and ask for warranty service.



GENERAL WARNING

BICYCLING IS A HAZARDOUS ACTIVITY THAT REQUIRES THAT THE RIDER STAY IN CONTROL OF HIS OR HER BICYCLE AT ALL TIMES. READING THIS MANUAL ENTIRELY, AND PROPERLY MAINTAINING YOUR BICYCLE AND SUSPENSION FORK AND REAR SHOCK, WILL REDUCE THE POSSIBILITY OF INJURY OR POSSIBLE DEATH. PRIOR TO RIDING YOUR BICYCLE, YOU SHOULD INSPECT YOUR SUSPENSION FORK TO ENSURE THAT NO DAMAGE HAS OCCURRED DURING THE COURSE OF RIDING. DO NOT RIDE YOUR BICYCLE IF THE FORK OR SHOCK SHOWS ANY SIGNS OF BENDING, CRACKING, LEAKING, OR IF IT IS MISSING ANY OF THE ORIGINALLY SUPPLIED COMPONENTS. ANY FALL FROM YOUR BICYCLE CAN RESULT IN SERIOUS INJURY OR EVEN DEATH. FOLLOWING THESE INSTRUCTIONS CAN HELP YOU REDUCE THE RISK OF BEING INJURED.

IF YOU ARE A MODERATE OR AGGRESSIVE OFF-ROAD RIDER, OR RIDE AT LEAST THREE TIMES A WEEK OVER ROUGH TERRAIN, ANSWER RECOMMENDS RETURNING YOUR SUSPENSION FORK EVERY 2 YEARS FOR A THOROUGH INSPECTION AND UPDATE. TAKE YOUR FORK TO A MANITOU AUTHORIZED DEALER WHO CAN ARRANGE FOR SHIPMENT TO ANSWER PRODUCTS, OR YOU MAY CALL ANSWER TO HAVE YOUR FORK SHIPPED DIRECTLY AT (661) 257-4411.

IMPORTANT: The Magnum fork is an off-road fork, and as such, does not come with proper reflectors for on-road use. Have your dealer or mechanic install proper reflectors to meet the Consumer Product Safety Commission's (C.P.S.C.) Requirements for Bicycles if the fork is going to be used on public roads at any time. If you have questions regarding C.P.S.C. Standards or would like to purchase a reflector bracket kit (Part Number 85-3674) contact your dealer.

CONSUMER SAFETY INFORMATION

1. Never remove or have the steerer tube or stanchions removed from the crown. The steerer tube and stanchions (inner legs) are press fit at the factory. Press fit inner legs have higher performance versus bolt-in inner legs, but can not be pressed out. Pressing them out will permanently damage the crown beyond repair and render it unsafe for any continued use.
2. Never attempt to thread a threadless steerer tube. Cutting threads will weaken the steerer tube and cause an unsafe condition. The only safe thing to do is to obtain the proper crown/steerer from your dealer, or contact Answer warranty at (661) 257-4411.
3. Any other alteration or modification to your fork should be considered unsafe. Contact Answer Technical Support prior to modifying your fork in any way for safety information.
4. Do not use the Magnum fork if any parts are broken, bent, cracked, or you suspect may be damaged. Contact your dealer or Answer Products Technical Support at (661) 257-4411 if you have any questions concerning the integrity or condition of your fork.
5. Answer Products recommends that you periodically inspect your fork for wear and damage. Inspect the crown, inner legs, outer legs dropout and brake arch areas for cracks or damage.

WARRANTY INFORMATION

Any Answer Products fork found by the factory to be defective in materials and/or workmanship within one year from the date of purchase will be repaired or replaced at the option of the manufacturer, free of charge, when received at the factory with proof of purchase, freight prepaid. This warranty does not cover breakage, bending, or damage that may result from crashes or falls. This warranty does not cover any fork that has been subject to misuse or whose serial number has been altered, defaced or removed. This warranty does not cover paint damage. Any modifications made by the user will render the warranty null and void. This warranty is expressly in lieu of all other warranties, and any implied are limited in duration to the same duration as the expressed warranty herein. Answer Products shall not be liable for any incidental or consequential damages.

If for any reason warranty work is necessary, return the fork to the place of purchase. In the USA, dealers should call Answer Products for a return authorization number (RA#) at (661) 257-4411 or (800) 423-0273. At that time, instructions for repair, return, or replacement shall be given. Customers in countries other than USA should contact their dealer or local distributor.

INSTALLATION INSTRUCTIONS

Ensure that the proper steerer tube has been delivered on your Magnum first. The steerer tube may need to be cut to length to fit your bicycle head tube. If you are not familiar with this procedure, or do not have the proper tools to cut the steerer tube, it is recommended that you seek a dealer with a qualified bicycle mechanic to perform installation.



WARNING

THE STEERER TUBE AND STANCHIONS (INNER LEGS) ARE A ONE-TIME PRECISION PRESS FIT AT THE FACTORY AND CANNOT BE REMOVED FROM THE CROWN. REPLACEMENT OF THE ENTIRE CROWN/STEERER ASSEMBLY MUST BE DONE TO CHANGE STEERER TUBE LENGTHS OR DIAMETERS. REMOVING AND REPLACING THE STEERER TUBE OR STANCHIONS WILL RESULT IN AN UNSAFE CONDITION AND SHOULD NEVER BE DONE.

FORK INSTALLATION

1. Remove the old fork from your bicycle.
2. Measure and cut the steerer tube to fit your bicycle head tube. You can use your old fork as a guide to how long you should cut the steerer tube to.
3. Remove the headset crown race from the old fork and press onto the Magnum steerer until the race is seated over the crown (Figure 1).
4. Clean and grease the headset bearings and races.
5. Install the lower bearings (if applicable) on fork crown race.
6. Insert the steerer tube into the head tube of the frame.
7. Install the upper bearings, stem spacers, and stem.
8. Install the stem cap and bolt. Tighten the bolt to headset manufacturer's specifications.
9. Install the handlebars to desired height and the torque stem pinch screws or stem clamping system to manufacturer's specifications.
10. Install the brakes and adjust per the manufacturer's instructions.
11. For all Magnums, adjust the front wheel quick release to clear the 0.275 (7 mm) thick secondary catch dropout. The quick release must be tightened after it is properly seated into the dropout counter bores to manufacturer's specifications. Insure that there is adequate thread engagement (4 or more threads with the release adjusted to lock).
12. Install the brake cable per manufacturer's instructions.

NOTE: 2001 Magnum and Magnum R forks are equipped with a secondary catch dropout, to retain the wheel in the fork in the event the quick release comes loose.



WARNING

WHEN INSTALLING THE WHEEL OR A NEW TIRE, CHECK TO MAKE SURE THE FORK ACHIEVES MINIMUM TIRE CLEARANCE. MEASURE FROM THE HIGHEST POINT ON THE TIRE TO THE BOTTOM OF THE CROWN. THE MINIMUM CLEARANCE ALLOWED IS: 3.11" (79MM) FOR A 76MM TRAVEL FORK. ANY CLEARANCE LESS THAN THIS CAN RESULT IN SERIOUS INJURY OR DEATH. FIGURE 2.

IMPORTANT: The Magnum should not be used if any parts appear to be or are damaged. Contact your local dealer or Answer Products for replacement parts.

MAINTENANCE

IMPORTANT: Use of fork boots is required to keep your Magnum fork performing well and the warranty in effect. Use of this fork without boots will shorten the life of the fork, decrease the time between maintenance intervals, reduce the performance and void the warranty. The only exception is a fork that is sold by Answer from the factory without boots.

Your Magnum fork requires periodic maintenance, cleaning and inspection. This is because moisture and contamination may build up inside the fork depending on the severity of riding conditions. To maintain top performance, it is recommended that the fork be periodically disassembled, cleaned, dried and re-greased using the Microlube grease ports located on the back of each outer leg (Figure 3). For information on how to properly service your fork, you will need the 2001 Magnum Service Manual P/N:85-3691.

IMPORTANT: When lubricating the fork with grease through the Microlube grease ports, it is important to note the grease is being forced between the upper and lower bushings. If the area is overfilled, the force of the grease may force the upper bushing and dust seal out. You should only insert grease to the level at which stiction is no longer felt.

IMPORTANT: Before every ride you should:

1. Ensure that quick release skewers are properly adjusted and tight.
2. Wipe the inner legs and clean and check entire fork for any obvious damage.
3. Check the headset for proper adjustment.
4. Ensure that the front brake cable is properly routed and check brake adjustment.

CHECKING OIL LEVEL

IMPORTANT: Maintaining the proper oil level in your TPC Sport-equipped fork is critical. TPC Sport is located in the right leg of your Magnum R fork. Not enough oil will allow foaming and reduce the performance. Too much oil will restrict travel and may cause damage to the system and create an unsafe riding condition. Finish reading this entire section prior to altering the oil level.

To check the oil level on the Magnum R, remove the compression assembly located in the top of the right leg. Leave the left side spring stack in place to keep the fork fully extended. Use a tape measure or "dip stick" to determine the oil level. The oil level for the Magnum R should be per following table. (See Figure 4.)

OIL LEVEL			
Fork Model	Maximum	Minimum	Recommended
Magnum R	3.80" (93 mm)	4.8" (122 mm)	4.20" (107 mm)

NOTE: Use Maxima SAE 5WT fork oil suspension fluid only.

ADJUSTING SPRING RATE

Magnum forks offer a wide adjustment range to suit individual riding preference and rider weight by simply changing the MCU and coil spring in the fork. Fine-tuning of the spring rate can be made by rotating the adjuster knobs located on top of the left fork leg. Rotating the knob clockwise will firm the ride and add preload to the spring stack. Rotating the knob counter clockwise will soften the ride and decrease preload on the spring stack. Four full revolutions will take the adjuster from full soft to the firmest setting.

RECOMMENDED SPRING RATES FOR 2001 MAGNUM FORKS

Rider Weight	Coil Spring	MCU Spring
100-140 lbs.	(1) 4 3/8 inch 100 pound coil	(1) 4-inch blue MCU
140-170 lbs.	(1) 4 3/8 inch 125 pound coil	(1) 4-inch red MCU
170-190 lbs.	(1) 4 3/8 inch 125 pound coil	(1) 4-inch yellow MCU
190-210 lbs.	(1) 4 3/8 inch 150 pound coil	(1) 4-inch red MCU
210+ lbs	(1) 4 3/8 inch 150 pound coil	(1) 4-inch yellow MCU

SPRING RATE FINE TUNING: Figure 5

NOTE: MCU's and springs used in pre-2000 model Manitou forks are NOT interchangeable with later versions of Manitou forks. Recommended spring kits are available through your dealer.

TUNING TPC SPORT

TPC Sport is not adjustable externally, but that doesn't mean you can't vary the feel of the fork; changing the fork oil weight in your TPC Sport-equipped fork will significantly alter the damping character of the fork. The standard fork fluid for Manitou forks is 5-weight Maxima, but 2.5-weight oil will decrease damping control, while 7.5-weight will increase damping control in the TPC sport system.

One thing to remember when changing standard fork fluid is that the increased or decreased oil weight will affect both compression and rebound damping equally. This means that while you may be slowing rebound down by say, adding heavier fork oil, you also may be adding compression damping to the point of the fork feeling harsh. The best thing to do is to experiment with different oil weights until you find that perfect setting for you.

NOTE: Since TPC Sport uses orifices (or holes) in the compression and rebound pistons to meter the flow of oil (and thus create damping), changing the orifice sizing may seem an obvious method to tuning TPC Sport. While doing this will produce significant changes in the damping of the fork, it is not recommended. Changing the size of the damping ports risks damaging the pistons, will void the warranty on the fork and will most likely compromise the performance of the fork as well.

Figures 6 and 7 are schematics of the Magnum and Magnum R fork models.

BUSHING & SEAL DETAIL

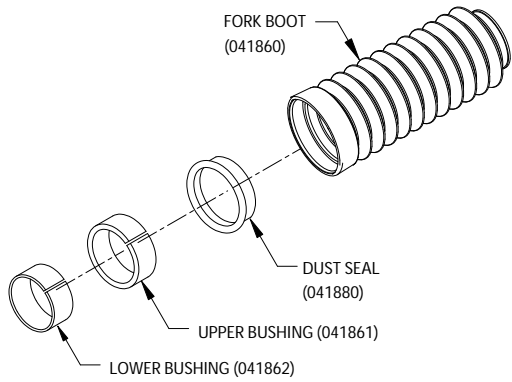

2001 MAGNUM FORK SCHEMATIC

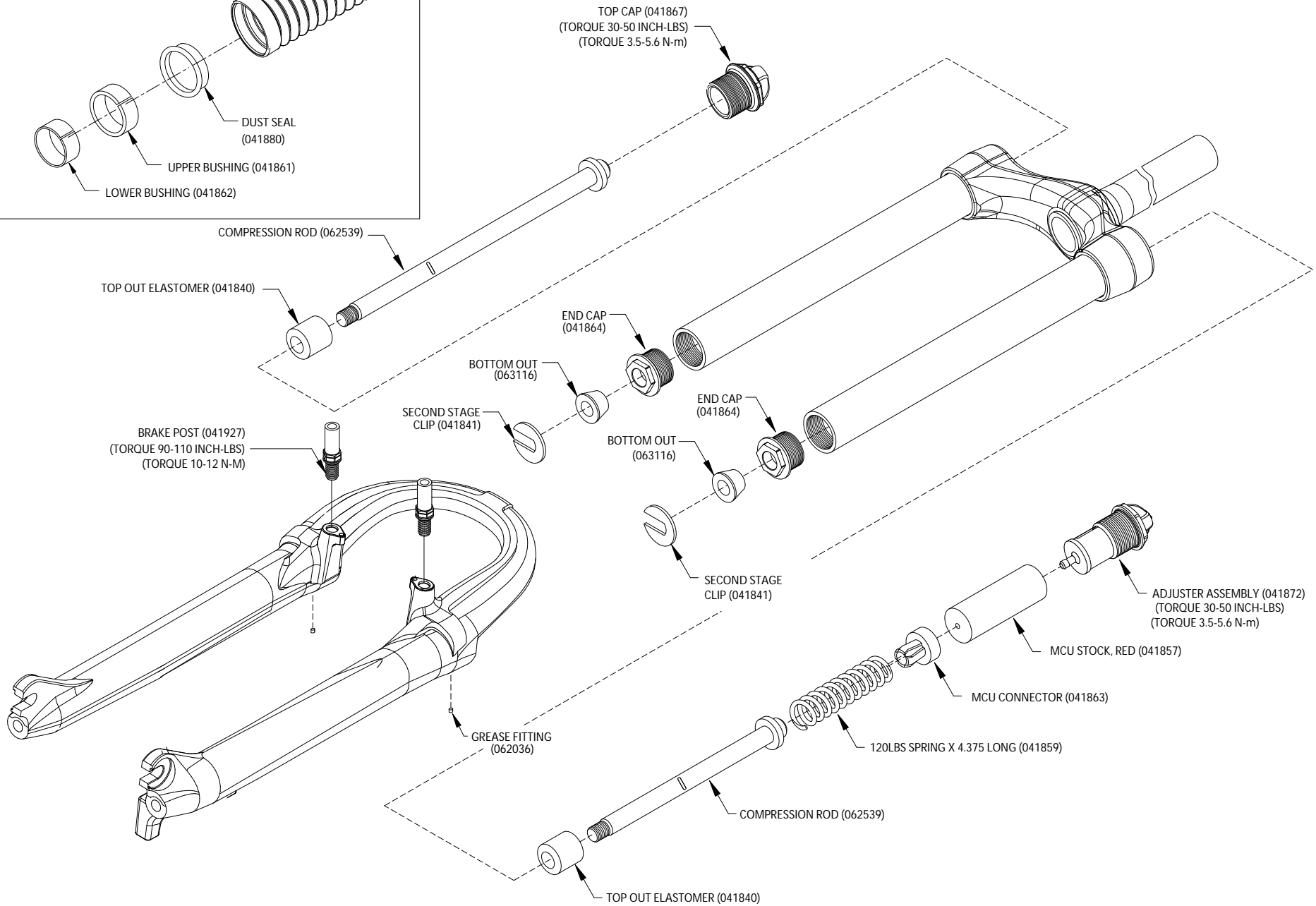

BUSHING & SEAL DETAIL

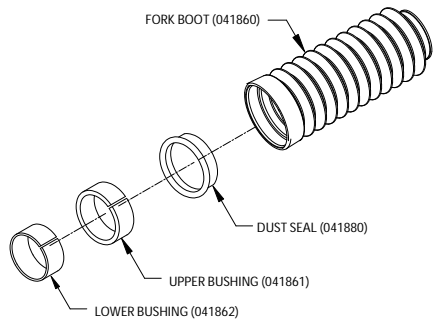

2001 MAGNUM R FORK SCHEMATIC

