

1 Race Installation
 Einbau des Steuersatzringes
 Instalación del anillo de rodadura
 Installation du jeu de direction
 Montaggio dell'anello della testa
 Installatie van loopring
 Instalação do canalete
 レースの取り付け

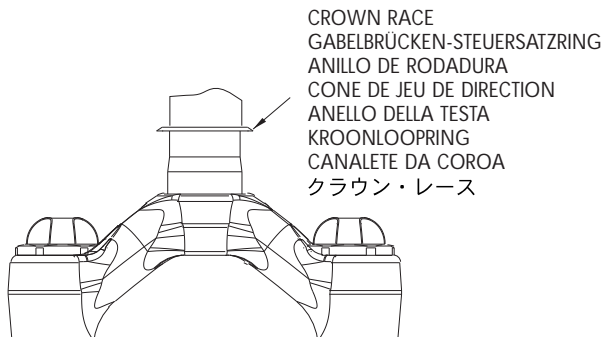

2 Tire clearance
 Reifenabstand
 Espacio libre de la cubierta
 Distance arceau/pneu
 Spazio libero del pneumatico
 Bandspeling
 Folga do pneu
 タイヤクリアランス

FORK MODEL GABELMODELL MODELO DE HORQUILLA MODELE DE FOURCHE MODELLO DI FORCELLA VORKMODEL MODELO DO GARFO フォーク・モデル	MINIMUM CLEARANCE MINDESTABSTAND ESPACIO LIBRE MINIMO JEU MINIMUM SPAZIO LIBERO MINIMO MINIMUMSPELING FOLGA MINIMA 最少クリアランス
80 mm travel forks	3.26" (83 mm)
Gabel mit 80 mm Auslenkung	83 mm
Horquillas con recorrido de 80 mm	83 mm
Fourches ayant une course de 80 mm	83 mm
Forcelle con corsa da 80 mm	83 mm
Loop van 80 mm	83 mm
Curso de 80 mm	83 mm

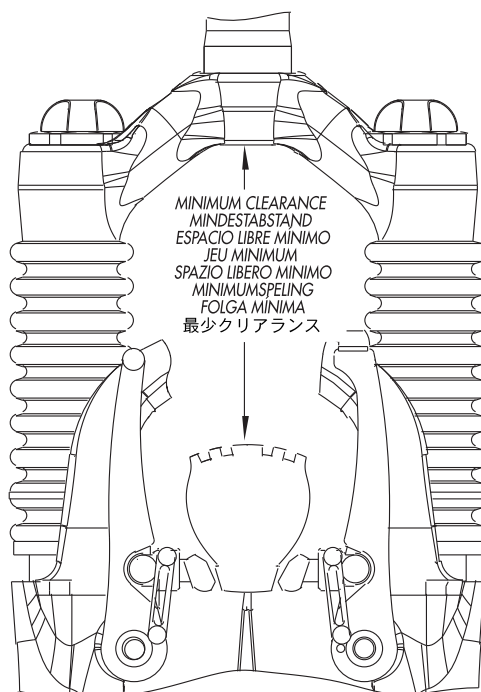

3

Grease port
Schmieröffnung
Orificio de engrasado
Graisseur
Apertura per l'ingrassaggio
Smeergat
Orificio de lubrificação

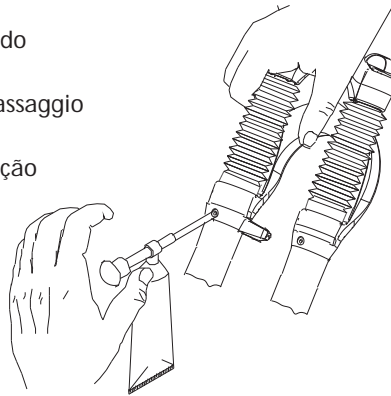

4

Oil level
Ölstand
Nivel del aceite
Niveau d'huile
Livello dell'olio
Oliepeil
Nível do óleo

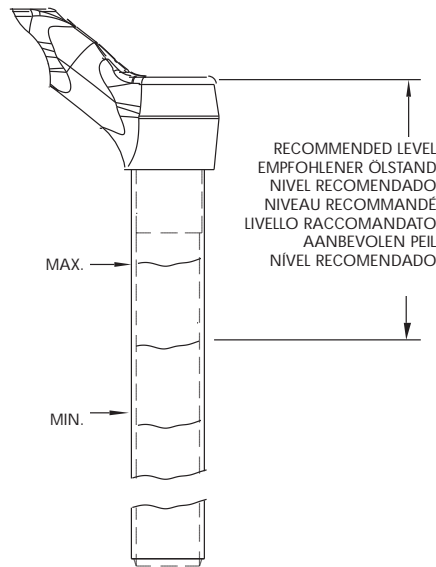

5

Fine tuning air/coil spring rate
Feinabstimmung der Luft-/
Schraubenfederrate
Ajuste de precisión de la
capacidad de resortes
neumáticos y helicoidales
Réglage du taux de raideur des
ressorts pneumatique/à bobine
Messa a punto pneumatica/
della molla di compressione
Fijnafstelling van lucht-/springveer
Ajuste de precisão da taxa de com-
pressão da mola
pneumática/helicoidal

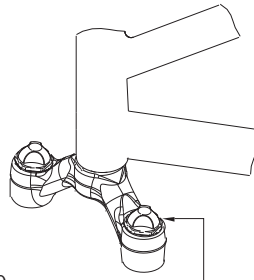

SCHRAEDER VALVE UNDER KNOB.
DAS VENTIL (SCHRAEDER VENTIL)
BEFINDET SICH UNTER DEM
DREHKNOPF.
LA VÁLVULA SCHRAEDER SE
ENCUENTRA DEBAJO DEL REGU-
LADOR.
LA VALVE SCHRAEDER EST SITUÉE
SOUS LE BOUTON.
LA VALVOLA SCHRAEDER VALVE È
SITUATA SOTTO LA MANOPOLA.
SCHRAEDER-KLEP BEVINDT ZICH
ONDER DE KNOP.
A VÁLVULA SCHRAEDER ESTÁ
LOCALIZADA EM BAIXO DO
BOTÃO.

6 Fine tuning compression damping – MARS Elite
Feinabstimmung der Druckstufendämpfung –
MARS Elite

Ajuste de precisión para el sistema de
amortiguación de compresión –
MARS Elite

Réglages fins de l'amortisse-
ment de la compression –
MARS Elite

Messa a punto del
gruppo compressione
di smorzamento –
MARS Elite

Fijnafstelling van drukdemping –
MARS Elite

Ajuste de precisão do amortecimento
de compressão – MARS Elite

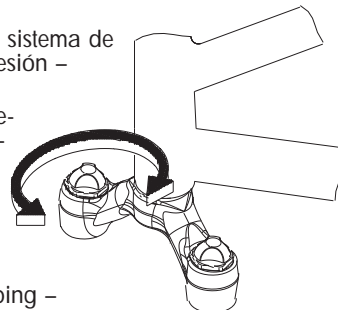

ROTATE
DREHEN
GIRAR
TOURNER

RUOTARE
DRAAIEN
GIRAR

7 Fine tuning compression damping – MARS Super
Feinabstimmung der Druckstufendämpfung –
MARS Super

Ajuste de precisión de amortiguación de compresión –
MARS Super

Réglages fins de l'amortissement de la compres-
sion – MARS Super

Messa a punto del gruppo compressione
di smorzamento – MARS Super

Fijnafstelling van drukdemping
– MARS Super

Ajuste de precisão do
amortecimento de
compressão –
MARS Super

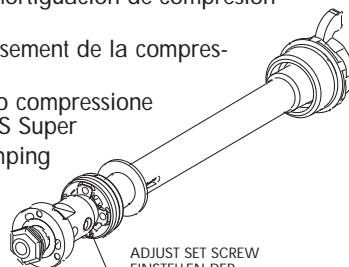

ADJUST SET SCREW
EINSTELLEN DER
STELLSCHRAUBE
GIRE EL TORNILLO DE AJUSTE
TOURNER LA VIS DE RÉGLAGE
REGOLARE LA VITE DI FERMO
STELSCHROEF BUSTELLEN
REGULE O PARAFUSO
DE AJUSTAGEM

8 Fine tuning rebound damping – MARS Elite and
MARS Super only

Feinabstimmung der Zugstufendämpfung – nur für
MARS Elite und MARS Super

Ajuste de precisión para la amortiguación de rebote –
MARS Elite y MARS Super solamente

Réglages fins de l'amortissement de la détente – MARS Elite
et MARS Super uniquement

Messa a punto dello smorzamento all'estensione –
MARS Elite e MARS Super

Fijnafstelling van terugveringdemping – uitsluitend MARS
Elite en MARS Super

Ajuste de precisão do ressalto de amortecimento do
– somente para o MARS Elite e MARS Super

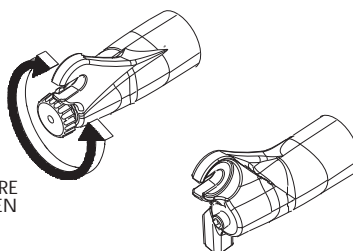

ROTATE
DREHEN
GIRAR
TOURNER

RUOTARE
DRAAIEN
GIRAR

AMERICAN MADE MANITOU SUSPENSION

CONGRATULATIONS ON CHOOSING THE LATEST IN SUSPENSION TECHNOLOGY AVAILABLE, A 2001 MANITOU MARS BUILT IN THE USA. WITH THIS FORK INSTALLED ON YOUR BIKE, YOU'LL BE ABLE TO RIDE FASTER AND HAVE MORE FUN. SOME WORDS ON YOUR NEW MARS BEFORE WE BEGIN. 2001 MARS FORKS USE MANITOU'S STATE-OF-THE-ART AIR-COIL SPRING SYSTEM. THE MARS LINE USES THE PATENTED TPC (TWIN PISTON CHAMBER) SYSTEM THAT SURPASSES ALL OTHER TYPES OF OIL-DAMPED SYSTEMS IN PERFORMANCE AND DURABILITY. MARS FORKS ALSO USE MANITOU'S QUICK AND EASY MICROLUBE SYSTEM, WHICH ALLOWS YOU TO LUBRICATE THE FORK VIA AN EXTERNAL FITTING ON THE BACK OF THE FORK. ALL MARS FORKS COME EQUIPPED WITH 74 MM POST-STYLE DISC BRAKE MOUNTS.

This MARS fork is fully assembled and ready to be installed onto your bicycle. It comes equipped with a 1 1/8-inch threadless steerer tube, and is available with a V-brake-style hangerless arch.

2001 MARS FORK LINE

MARS	80 MM TRAVEL / AIR-COIL SPRING / TPC SPORT DAMPING / SINGLE HOLLOW CROWN
MARS ELITE	80 MM TRAVEL / AIR-COIL SPRING / TPC DAMPING / SINGLE HOLLOW CROWN
MARS SUPER	80 MM TRAVEL / AIR-COIL SPRING / ANTI-BOB / TPC DAMPING / SINGLE HOLLOW CROWN

One last note. If you lose this manual or want to take a look at the MARS Service Manual or MRD Tuning Manual, head straight for the web at www.answerproducts.com or call (661) 257-4411 and ask for warranty service.

! GENERAL WARNING BICYCLING IS A HAZARDOUS ACTIVITY THAT REQUIRES THAT THE RIDER STAY IN CONTROL OF HIS OR HER BICYCLE AT ALL TIMES. READING THIS MANUAL ENTIRELY AND PROPERLY MAINTAINING YOUR BICYCLE AND SUSPENSION FORK AND REAR SHOCK WILL REDUCE THE POSSIBILITY OF INJURY OR POSSIBLE DEATH. PRIOR TO RIDING YOUR BICYCLE, YOU SHOULD INSPECT YOUR SUSPENSION FORK TO ENSURE THAT NO DAMAGE HAS OCCURRED DURING THE COURSE OF RIDING. DO NOT RIDE YOUR BICYCLE IF THE FORK OR SHOCK SHOWS ANY SIGNS OF BENDING, CRACKING, LEAKING OR IF IT IS MISSING ANY OF THE ORIGINALLY SUPPLIED COMPONENTS. ANY FALL FROM YOUR BICYCLE CAN RESULT IN SERIOUS INJURY OR EVEN DEATH. FOLLOWING THESE INSTRUCTIONS CAN HELP YOU REDUCE THE RISK OF BEING INJURED.

IF YOU ARE A MODERATE OR AGGRESSIVE OFF-ROAD RIDER, OR RIDE AT LEAST THREE TIMES A WEEK OVER ROUGH TERRAIN, ANSWER RECOMMENDS RETURNING YOUR SUSPENSION FORK EVERY 2 YEARS FOR A THOROUGH INSPECTION AND UPDATE. TAKE YOUR FORK TO A MANITOU AUTHORIZED DEALER WHO CAN ARRANGE FOR SHIPMENT TO ANSWER PRODUCTS, OR YOU MAY CALL ANSWER TO HAVE YOUR FORK SHIPPED DIRECTLY AT (661) 257-4411.

IMPORTANT: The MARS fork is an off-road fork, and as such, does not come with proper reflectors for on-road use.

CONSUMER SAFETY INFORMATION

1. Never remove or have the steerer tube or stanchions removed from the crown. The steerer tube and stanchions (inner legs) are press fit at the factory. Press fit inner legs have a higher performance versus bolt-in inner legs, but cannot be pressed out. Pressing them out will permanently damage the crown beyond repair and render it unsafe for any continued use.
2. Never attempt to thread a threadless steerer tube. Cutting threads will weaken the steerer tube and cause an unsafe condition. The only safe thing to do is to obtain the proper crown/steerer from your dealer, or contact Answer warranty at (661) 257-4411.
3. Any other alteration or modification to your fork should be considered unsafe. Contact Answer Technical Support prior to modifying your fork in any way for safety information.
4. Do not use the MARS fork if any parts are broken, bent, cracked, or you suspect may be damaged. Contact your dealer or Answer Warranty at (661) 257-4411 if you have any questions concerning the integrity or condition of your fork.
5. Answer Products recommends that you periodically inspect your fork for wear and damage. Inspect the crown, inner legs, outer legs dropout and brake arch areas for cracks or damage.

WARRANTY INFORMATION

Any Answer Products fork found by the factory to be defective in materials and/or workmanship within one year from the date of purchase will be repaired or replaced at the option of the manufacturer, free of charge, when received at the factory with proof of purchase, freight prepaid. This warranty does not cover breakage, bending or damage that may result from crashes or falls. This warranty does not cover any fork that has been subject to misuse or whose serial number has been altered, defaced or removed. This warranty does not cover paint damage. Any modifications made by the user will render the warranty null and void. This warranty is expressly in lieu of all other warranties, and any implied are limited in duration to the same duration as the expressed warranty herein. Answer Products shall not be liable for any incidental or consequential damages.

If for any reason warranty work is necessary, return the fork to the place of purchase. In the USA, dealers should call Answer Products for a return authorization number (RA#) at (661) 257-4411 or (800) 423-0273. At that time, instructions for repair, return, or replacement shall be given. Customers in countries other than USA should contact their Manitou dealer or local distributor.

INSTALLATION INSTRUCTIONS

Ensure that the proper steerer tube has been delivered on your MARS first. The steerer tube may need to be cut to length to fit your bicycle head tube. If you are not familiar with this procedure or do not have the proper tools to cut the steerer tube, it is recommended that you seek a dealer with a qualified bicycle mechanic to perform the installation.

! WARNING THE STEERER TUBE AND STANCHIONS (INNER LEGS) ARE A ONE-TIME PRECISION PRESS FIT AT THE FACTORY AND CANNOT BE REMOVED FROM THE CROWN. REPLACEMENT OF THE ENTIRE CROWN/STEERER ASSEMBLY MUST BE DONE TO CHANGE STEERER TUBE LENGTHS OR DIAMETERS. REMOVING AND REPLACING THE STEER TUBE OR STANCHIONS WILL RESULT IN AN UNSAFE CONDITION AND SHOULD NEVER BE DONE.

FORK INSTALLATION

1. Remove the old fork from your bicycle.
2. Measure and cut the steerer tube to fit your bicycle head tube. You can use your old fork as a guide to how long you should cut the steerer tube.
3. Remove the headset crown race from the old fork and press onto the MARS steerer until the race is seated over the crown (Figure 1).
4. Clean and grease the headset bearings and races.
5. Install the lower bearings (if applicable) on fork crown race.
6. Insert the steerer tube into the head tube of the frame.
7. Install the upper bearings, stem spacers and stem.
8. Install the stem cap and bolt. Tighten the bolt to headset manufacturer's specifications.
9. Install the stem/handlebar assembly and the torque stem pinch screws or stem clamping system to manufacturer's specifications.
10. Install the brakes and adjust per the manufacturer's instructions.
11. Adjust the front wheel quick release to clear the 0.275 (7 mm) thick secondary catch dropout. The quick release must be tightened after it is properly seated into the dropout counter bores to manufacturer's specifications. Insure that there is adequate thread engagement (4 or more threads with the release adjusted to lock).
12. Install the brake cable per manufacturer's instructions.

NOTE: 2001 MARS forks are equipped with a secondary catch dropout to retain the wheel in the fork in the event the quick release comes loose.

! WARNING WHEN INSTALLING THE WHEEL OR A NEW TIRE, CHECK TO MAKE SURE THE FORK ACHIEVES MINIMUM TIRE CLEARANCE. MEASURE FROM THE HIGHEST POINT ON THE TIRE TO THE BOTTOM OF THE CROWN. THE MINIMUM CLEARANCE ALLOWED IS: 3.26" (83 MM) FOR 80 MM TRAVEL FORKS ANY CLEARANCE LESS THAN THIS CAN RESULT IN SERIOUS INJURY OR DEATH. FIGURE 2

IMPORTANT: The MARS should not be used if any parts appear to be or are damaged. Contact your local dealer or Answer Products for replacement parts.

MAINTENANCE

IMPORTANT:

1. Use of fork boots is recommended to keep your MARS fork performing at its optimum for extended service cycles, and maintaining maximum life of fork.
2. Use of this fork without fork boots will require frequent service intervals to maintain performance and normal life of fork.
3. Warranty will be void if fork is found to show that boots were not in place and frequent service was not performed.

Your MARS fork requires periodic maintenance, cleaning and inspection. This is because moisture and contamination may build up inside the fork depending on the severity of riding conditions. To maintain top performance, it is recommended that the fork be periodically disassembled, cleaned, dried and re-greased using the Microlube grease ports located on the back of each outer leg (Figure 3). For information on how to properly service your fork, you will need the 2001 MARS Service Manual P/N: 85-3694.

IMPORTANT: When lubricating the fork with Prep M grease through the Microlube grease ports, it is important to note the grease is being forced between the upper and lower bushings. If the area is overfilled the force of the grease may force the upper bushing and dust seal out. You should only insert grease to a maximum of 20 pumps.

IMPORTANT: Before every ride you should:

1. Ensure that quick release skewers are properly adjusted and tight.
2. Wipe the inner legs and clean and check the entire fork for any obvious damage.
3. Check the headset for proper adjustment.
4. Ensure that the front brake cable is properly routed and check brake adjustment.

CHECKING OIL LEVEL

IMPORTANT: Maintaining the proper oil level in your TPC-equipped fork is critical. TPC is located in the right leg of your MARS fork. Not enough oil will allow foaming and reduce the performance. Too much oil will restrict travel and may cause damage to the system and create an unsafe riding condition. Finish reading this entire section prior to altering the oil level.

To check the oil level, remove the compression assembly located in the top of the right leg. Leave the left side fully charged with air to keep the fork fully extended. Use a tape measure or "dip stick" to determine the oil level. The oil level should be per the following table. (See Figure 4.)

Fork Model	OIL LEVEL		
	Recommended	Maximum	Minimum
MARS	4.50" (114 mm)	4.00" (101 mm)	5.00" (127 mm)
MARS Elite	4.00" (101 mm)	3.75" (95 mm)	4.25" (108 mm)
MARS Super	3.75" (95 mm)	3.50" (89 mm)	4.00" (102 mm)

NOTE: Use Maxima SAE 5WT fork oil suspension fluid only.

AIR/COIL SPRING RATE TUNING

All 2001 MARS forks use a combination of air and a coil spring. The air spring is adjustable via a Schraeder valve located on top of the left leg. The positive coil spring can also be switched with stiffer or softer versions to accommodate for different rider styles and terrain. There's also a coil negative spring, but it is available in one rate only and is designed to be preloaded automatically as the positive air spring pressure is increased (in other words, you don't need to do anything to tune it).

The air/coil system is both lightweight and produces a supple, but progressive spring curve because of the use of two spring materials. The spring system in action functions like this: When the fork compresses, the coil spring compresses first. This is because the coil spring has a very low breakaway threshold (it moves with just one pound of pressure applied) and thus provides initial suppleness with the fork. The negative spring also helps provide initial suppleness because it helps actuate the air spring (a negative spring works to pull the fork together, where a positive spring is keeping the fork extended). In the middle portion of the travel, the fork transitions from the coil spring to the air spring. Near the end of the fork's travel, the air spring's progressive nature provides resistance to bottoming.

Recommended Spring Rates for 2001 MARS Forks

Rider Weight	Air Spring	Coil Spring
under 115 lbs.	80 psi +/- 5 psi (5.5 bar +/- 0.3 bar)	(1) 3" blue 80 pound coil spring
115-145 lbs.	100 psi +/- 5 psi (6.9 bar +/- 0.3 bar)	(1) 3" red 100 pound coil spring
145-175 lbs.	120 psi +/- 5 psi (8.3 bar +/- 0.3 bar)	(1) 3" red 100 pound coil spring
175-205 lbs.	140 psi +/- 5 psi (9.7 bar +/- 0.3 bar)	(1) 3" yellow 120 pound coil spring
205-230 lbs.	160 psi +/- 5 psi (11.0 bar +/- 0.3 bar)	(1) 3" yellow 120 pound coil spring
230 + lbs.	180 psi +/- 5 psi (12.4 bar +/- 0.3 bar)	(1) 3" black 150 pound coil spring

SPRING RATE FINE TUNING: Figure 5

NOTE: MCU's and springs used in pre-2001 model Manitou forks are NOT interchangeable with later versions of Manitou forks. Recommended spring kits are available through your dealer.

ADJUSTING DAMPING FOR MARS ELITE AND SUPER

COMPRESSION DAMPING FINE TUNING FOR MARS ELITE: Figure 6

To adjust the compression damping on your MARS Elite fork, simply rotate the compression damping knob located on top of the right leg. Rotating the knob clockwise will increase damping, while rotating the knob counterclockwise will reduce damping. Excessive damping (or an overly stiff spring rate) will give you a harsh ride over sharp bumps like rocky sections, but will handle large hits like G-outs well. Insufficient compression damping (or an overly soft spring rate) will cause the fork to bottom out on large hit G-outs and bob a little while climbing, but feel plush on the sharp hits. A correctly adjusted fork will perform well in all conditions.

COMPRESSION DAMPING FINE TUNING FOR MARS SUPER : Figure 7

To adjust the compression damping for the MARS Super, remove the Anti-Bob compression damping assembly from the top of the right leg. Adjust the set screw on the valve seat in to increase compression damping and out to reduce the compression damping. Try adjusting one half turn at a time.

REBOUND DAMPING FINE TUNING MARS ELITE AND MARS SUPER: Figure 8

To adjust the rebound damping on your MARS Elite and Super fork, simply rotate the rebound damping knob located on the bottom of the right leg. Rotating the knob clockwise will increase the damping, while rotating the knob counterclockwise will reduce the damping. Excessive damping (or an overly soft spring rate) will give you a harsh ride over repetitive bumps (like braking bumps) because the fork will pack up and sit too deep in the travel under normal riding conditions. Insufficient rebound damping will make the fork overly active and may even cause the fork to top out (a slight thumping noise when the fork extends completely). We suggest that you try adjusting your fork on the very active side, with minimum rebound damping. Then try it over a variety of terrain and tune in more rebound from there.

TUNING TPC SPORT

The TPC Sport damping found on the MARS model is not adjustable externally, but that doesn't mean you can't vary the feel of the fork; changing the fork oil weight in your TPC Sport-equipped fork will significantly alter the damping character of the fork. The standard fork fluid for Manitou forks is 5-weight Maxima, but 2.5-weight oil will decrease damping control, while 7.5-weight will increase damping in the TPC Sport system.

One thing to remember when changing standard fork fluid is that the increased or decreased oil weight will affect both compression and rebound damping equally. This means that while you may be slowing rebound down by say, adding heavier fork oil, you also may be adding compression damping to the point of the fork feeling harsh. The best thing to do is to experiment with different oil weights until you find that perfect setting for you.

NOTE: Since TPC Sport uses orifices (or holes) in the compression and rebound pistons to meter the flow of oil (and thus create damping), changing the orifice sizing may seem an obvious method to tuning TPC Sport. While doing this will produce significant changes in the damping of the fork, it is not recommended. Changing the size of the damping ports risks damaging the pistons, will void the warranty on the fork and will most likely compromise the performance of the fork as well.

Figures 9, 10 & 11 are schematics of the MARS, MARS Elite & MARS Super fork models.

ANTI-BOB SYSTEM

Anti-Bobs are available for all MARS models and is stock on the MARS Super. By turning the knob 1/4 turn counterclockwise, the front fork will have regular TPC suspension. By turning the knob 1/4 turn clockwise, the fork will have extreme damping. Partial Anti-Bob can be used by turning the knob between the on and off positions. A safety blow-off valve will open under extreme conditions to allow some movement.

