



p/n: 042028

# **MANITOU**

**2001 OWNER'S MANUAL**

**SX**

**SX100mm**

**SXE**

**SXR**



**answerproducts**  
incorporated

28209 Avenue Stanford, Valencia, California 91355-3984 • Phone: 661.257.4411 • Sales Fax: 661.294.4179

**3**

Grease port  
 Schmieröffnung  
 Orificio de engrasado  
 Graisseur  
 Apertura per l'ingrassaggio  
 Smeergat  
 Orifício de lubrificação

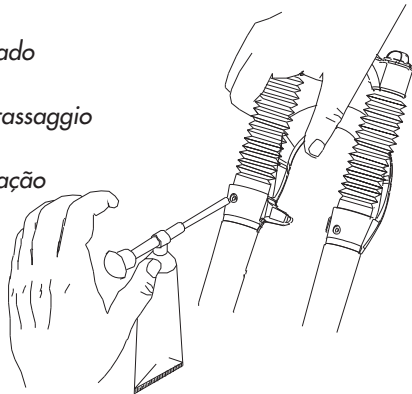
**5**

Fine tuning compression spring  
 Feinabstimmung der Druckfeder  
 Ajustes de precisión al resorte de compresión  
 Réglages fins des ressorts de compression  
 Messa a punto della molla di compressione  
 Fijnafstelling van drukveer  
 Mola de compressão de ajuste preciso

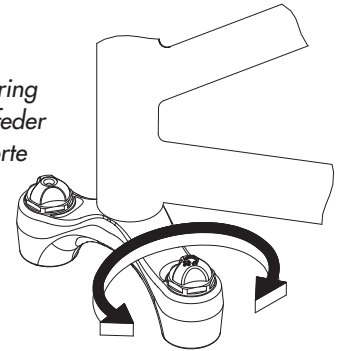

ROTATE  
 DREHEN  
 GIRAR  
 TOURNER

RUOTARE  
 DRAAIEN  
 GIRAR

**4**

Oil level  
 Ölstand  
 Nivel del aceite  
 Niveau d'huile  
 Livello dell'olio  
 Oliepeil  
 Nivel do óleo

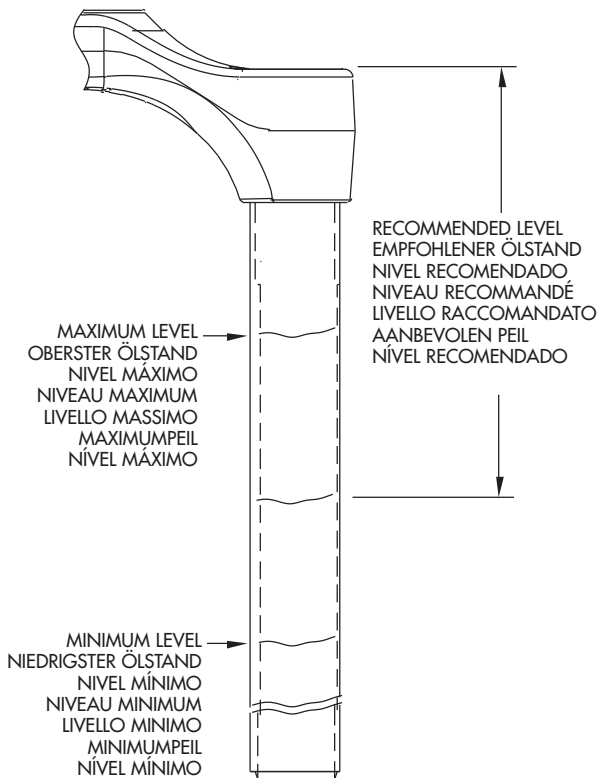
**6**

Fine tuning compression damping  
 Feinabstimmung der Druckstufendämpfung  
 Ajuste de precisión para el sistema de amortiguación de compresión  
 Réglages fins de l'amortissement de la compression  
 Messa a punto del gruppo compressione di smorzamento  
 Fijnafstelling van drukdemping  
 Ajuste de precisão do amortecimento de compressão

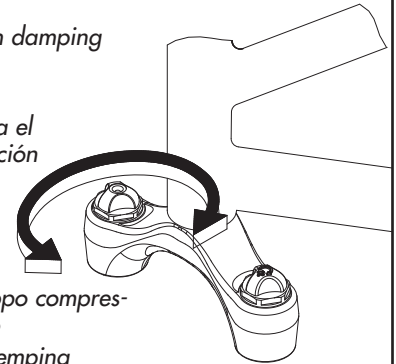

ROTATE  
 DREHEN  
 GIRAR  
 TOURNER

RUOTARE  
 DRAAIEN  
 GIRAR

**7**

Fine tuning rebound damping  
 Feinabstimmung der Zugstufendämpfung  
 Ajuste de precisión para la amortiguación de rebote  
 Réglages fins de l'amortissement de la détente  
 Messa a punto dello smorzamento all'estensione  
 Fijnafstelling van terugveringdemping  
 Ajuste de precisão do ressalto de amortecimento

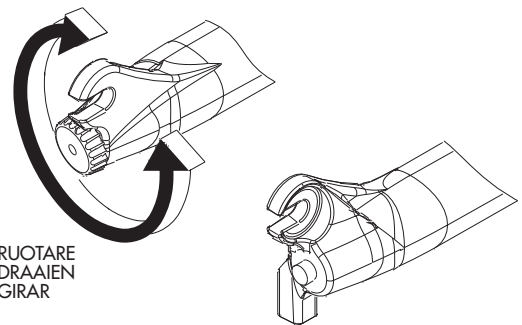

ROTATE  
 DREHEN  
 GIRAR  
 TOURNER

RUOTARE  
 DRAAIEN  
 GIRAR

**1**

Race Installation  
 Einbau des Steuersatzringes  
 Instalación del anillo de rodadura  
 Installation du jeu de direction  
 Montaggio dell'anello della testa  
 Installatie van loopring  
 Instalação do canalete

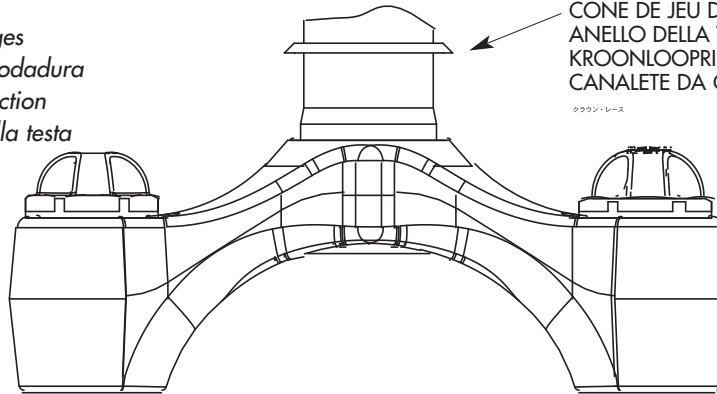

CROWN RACE  
 GABELBRÜCKEN-STEUERSATZRING  
 ANILLO DE RODADURA  
 CONE DE JEU DE DIRECTION  
 ANELLO DELLA TESTA  
 KROONLOOPRING  
 CANALETE DA COROA

クワラン・レース

**2**

Tire clearance  
 Reifenabstand  
 Espacio libre de la cubierta  
 Distance arceau/pneu  
 Spazio libero del pneumatico  
 Bandspeling  
 Folga do pneu

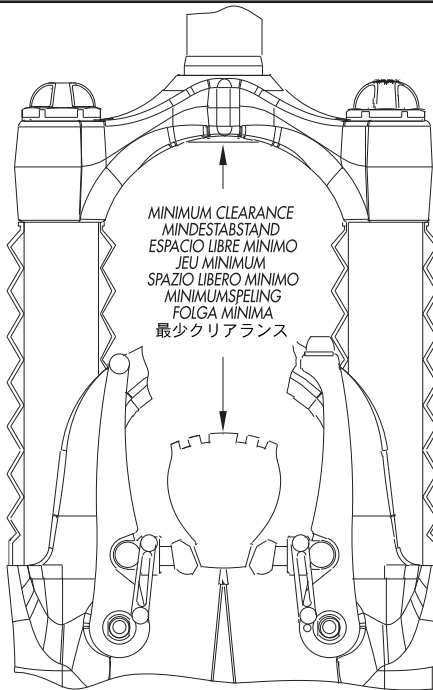

MINIMUM CLEARANCE  
 MINDESTABSTAND  
 ESPACIO LIBRE MÍNIMO  
 JEU MINIMUM  
 SPAZIO LIBERO MINIMO  
 MINIMUMSPELING  
 FOLGA MINIMA  
 最少クリアランス

FORK MODEL  
 GABELMODELL  
 MODELO DE HORQUILLA  
 MODELE DE FOURCHE  
 MODELLO DI FORCELLA  
 VORKMODEL  
 MODELO DO GARFO

フォーク・モデル

最少クリアランス

MINIMUM CLEARANCE  
 MINDESTABSTAND  
 ESPACIO LIBRE MÍNIMO  
 JEU MINIMUM  
 SPAZIO LIBERO MINIMO  
 MINIMUMSPELING  
 FOLGA MINIMA

80 mm travel forks	3.26" (83 mm)
100 mm travel forks	4.05" (103 mm)

Gabel mit 80 mm Auslenkung	83 mm
Gabel mit 100 mm Auslenkung	103 mm

Horquillas con recorrido de 80 mm	83 mm
Horquillas con recorrido de 100 mm	103 mm

Fourches ayant une course de 80 mm	83 mm
Fourches ayant une course de 100 mm	103 mm

Forcelle con corsa da 80 mm	83 mm
Forcelle con corsa da 100 mm	103 mm

Loop van 80 mm	83 mm
Loop van 100 mm	103 mm

Curso de 80 mm	83 mm
Curso de 100 mm	103 mm

	83 mm
	103 mm

## AMERICAN MADE MANITOU SUSPENSION

CONGRATULATIONS ON CHOOSING THE LATEST IN SUSPENSION TECHNOLOGY AVAILABLE, A 2001 MANITOU SX BUILT IN THE USA. WITH THIS FORK INSTALLED ON YOUR BIKE, YOU'LL BE ABLE TO RIDE FASTER AND HAVE MORE FUN. SOME WORDS ON YOUR NEW SX BEFORE WE BEGIN. 2001 SX, SX 100MM AND SX R FORKS USE MANITOU'S PATENTED TPC (TWIN PISTON CHAMBER) SYSTEM THAT SURPASSES ALL OTHER TYPES OF OIL-DAMPED SYSTEMS IN PERFORMANCE AND DURABILITY. SX FORKS ALSO USE MANITOU'S QUICK AND EASY MICROLUBE SYSTEM, WHICH ALLOWS YOU TO LUBRICATE THE FORK VIA AN EXTERNAL FITTING ON THE BACK OF THE FORK. ALL MANITOU FORKS COME EQUIPPED WITH 74MM POST-STYLE DISC BRAKE MOUNTS.

This SX fork is fully assembled and ready to be installed onto your bicycle. It comes equipped with a 1 1/8-inch threadless steerer tube, and is available with a V-brake-style hangerless arch.

### 2001 SX FORK LINE

SX E.....80MM TRAVEL/COIL-MCU SPRING/TPC PLUS DAMPING/  
SINGLE CROWN

SX/SX 100MM...80MM/100MM TRAVEL/TPC SPORT DAMPING/SINGLE CROWN

SX R .....80MM TRAVEL/TPC DAMPING/SINGLE CROWN

One last note. If you lose this manual, or want to take a look at the SX Service Manual or MRD Tuning Manual, head straight for the web at [www.answerproducts.com](http://www.answerproducts.com) or call (661) 257-4411 and ask for warranty service.

**GENERAL WARNING** BICYCLING IS A HAZARDOUS ACTIVITY THAT REQUIRES THAT THE RIDER STAY IN CONTROL OF HIS OR HER BICYCLE AT ALL TIMES. READING THIS MANUAL ENTIRELY, AND PROPERLY MAINTAINING YOUR BICYCLE AND SUSPENSION FORK AND REAR SHOCK, WILL REDUCE THE POSSIBILITY OF INJURY OR POSSIBLE DEATH. PRIOR TO RIDING YOUR BICYCLE, YOU SHOULD INSPECT YOUR SUSPENSION FORK TO ENSURE THAT NO DAMAGE HAS OCCURRED DURING THE COURSE OF RIDING. DO NOT RIDE YOUR BICYCLE IF THE FORK OR SHOCK SHOWS ANY SIGNS OF BENDING, CRACKING, LEAKING, OR IF IT IS MISSING ANY OF THE ORIGINALLY SUPPLIED COMPONENTS. ANY FALL FROM YOUR BICYCLE CAN RESULT IN SERIOUS INJURY OR EVEN DEATH. FOLLOWING THESE INSTRUCTIONS CAN HELP YOU REDUCE THE RISK OF BEING INJURED.

IF YOU ARE A MODERATE OR AGGRESSIVE OFF-ROAD RIDER, OR RIDE AT LEAST THREE TIMES A WEEK OVER ROUGH TERRAIN, ANSWER RECOMMENDS RETURNING YOUR SUSPENSION FORK EVERY 2 YEARS FOR A THOROUGH INSPECTION AND UPDATE. TAKE YOUR FORK TO A MANITOU AUTHORIZED DEALER WHO CAN ARRANGE FOR SHIPMENT TO ANSWER PRODUCTS, OR YOU MAY CALL ANSWER TO HAVE YOUR FORK SHIPPED DIRECTLY AT (661) 257-4411.

**IMPORTANT:** The SX fork is an off-road fork, and as such, does not come with proper reflectors for on road use. Have your dealer or mechanic install proper reflectors to meet the Consumer Product Safety Commission's (C.P.S.C.) Requirements for Bicycles if the fork is going to be used on public roads at any time. If you have questions regarding C.P.S.C. Standards or would like to purchase a reflector bracket kit (Part Number 85-3674) contact your dealer.

## CONSUMER SAFETY INFORMATION

1. Never remove or have the steerer tube or stanchions removed from the crown. The steerer tube and stanchions (inner legs) are press fit at the factory. Press fit inner legs have higher performance versus bolt-in inner legs, but can not be pressed out. Pressing them out will permanently damage the crown beyond repair and render it unsafe for any continued use.
2. Never attempt to thread a threadless steerer tube. Cutting threads will weaken the steerer tube and cause an unsafe condition. The only safe thing to do is to obtain the proper crown/steerer from your dealer, or contact Answer warranty at (661) 257-4411.
3. Any other alteration or modification to your fork should be considered unsafe. Contact Answer Technical Support prior to modifying your fork in any way for safety information.
4. Do not use the SX fork if any parts are broken, bent, cracked, or you suspect may be damaged. Contact your dealer or Answer Products Technical Support at (661) 257-4411 if you have any questions concerning the integrity or condition of your fork.
5. Answer Products recommends that you periodically inspect your fork for wear and damage. Inspect the crown, inner legs, outer legs dropout and brake arch areas for cracks or damage.

## WARRANTY INFORMATION

Any Answer Products fork found by the factory to be defective in materials and/or workmanship within one year from the date of purchase will be repaired or replaced at the option of the manufacturer, free of charge, when received at the factory with proof of purchase, freight prepaid. This warranty does not cover breakage, bending, or damage that may result from crashes or falls. This warranty does not cover any fork that has been subject to misuse or whose serial number has been altered, defaced or removed. This warranty does not cover paint damage. Any modifications made by the user will render the warranty null and void. This warranty is expressly in lieu of all other warranties, and any implied are limited in duration to the same duration as the expressed warranty herein. Answer Products shall not be liable for any incidental or consequential damages.

If for any reason warranty work is necessary, return the fork to the place of purchase. In the USA, dealers should call Answer Products for a return authorization number (RA#) at (661) 257-4411. At that time, instructions for repair, return, or replacement shall be given. Customers in countries other than USA should contact their dealer or local distributor.

## INSTALLATION INSTRUCTIONS

Ensure that the proper steerer tube has been delivered on your SX first. The steerer tube may need to be cut to length to fit your bicycle head tube. If you are not familiar with this procedure, or do not have the proper tools to cut the steerer tube, it is recommended that you seek a dealer with a qualified bicycle mechanic to perform installation.

**WARNING** THE STEERER TUBE AND STANCHIONS (INNER LEGS) ARE A ONE-TIME PRECISION PRESS FIT AT THE FACTORY AND CANNOT BE REMOVED FROM THE CROWN. REPLACEMENT OF THE ENTIRE CROWN/STEERER ASSEMBLY MUST BE DONE TO CHANGE STEERER TUBE LENGTHS OR DIAMETERS. REMOVING AND REPLACING THE STEERER TUBE OR STANCHIONS WILL RESULT IN AN UNSAFE CONDITION AND SHOULD NEVER BE DONE.

### FORK INSTALLATION

1. Remove the old fork from your bicycle.
2. Measure and cut the steerer tube to fit your bicycle head tube. You can use your old fork as a guide to how long you should cut the steerer tube to.
3. Remove the headset crown race from the old fork and press onto the SX steerer until the race is seated over the crown (Figure 1).
4. Clean and grease the headset bearings and races.
5. Install the lower bearings (if applicable) on fork crown race.
6. Insert the steerer tube into the head tube of the frame.
7. Install the upper bearings, stem spacers, and stem.
8. Install the stem cap and bolt. Tighten the bolt to headset manufacturer's specifications.
9. Install the handlebars to desired height and the torque stem pinch screws or stem clamping system to manufacturer's specifications.
10. Install the brakes and adjust per the manufacturer's instructions.
11. For all SX's adjust the front wheel quick release to clear the 0.275 (7 mm) thick secondary catch dropout. The quick release must be tightened after it is properly seated into the dropout counter bores to manufacturer's specifications. Insure that there is adequate thread engagement (4 or more threads with the release adjusted to lock).
12. Install the brake cable per manufacturer's instructions.

*NOTE: 2001 SX E, SX, SX 100MM, and SX R forks are equipped with a secondary catch dropout to retain the wheel in the fork in the event the quick release comes loose.*

**WARNING** WHEN INSTALLING THE WHEEL OR A NEW TIRE, CHECK TO MAKE SURE THE FORK ACHIEVES MINIMUM TIRE CLEARANCE. MEASURE FROM THE HIGHEST POINT ON THE TIRE TO THE BOTTOM OF THE CROWN. THE MINIMUM CLEARANCE ALLOWED IS:  
**3.26" (83MM) FOR 80MM TRAVEL FORKS**  
**4.05" (103MM) FOR 100 MM TRAVEL FORKS**  
**ANY CLEARANCE LESS THAN THIS CAN RESULT IN SERIOUS INJURY OR DEATH. FIGURE 2**

**IMPORTANT:** The SX should not be used if any parts appear to be or are damaged. Contact your local dealer or Answer Products for replacement parts.

## MAINTENANCE

**IMPORTANT:** Use of fork boots is required to keep your SX fork performing well and the warranty in effect. Use of this fork without boots will shorten the life of the fork, decrease the time between maintenance intervals, reduce the performance and void the warranty. The only exception is a fork that is sold by Answer from the factory without boots.

Your SX fork requires periodic maintenance, cleaning and inspection. This is because moisture and contamination may build up inside the fork depending on the severity of riding conditions. To maintain top performance, it is recommended that the fork be periodically disassembled, cleaned, dried and re-greased using the Microlube grease ports located on the back of each outer leg (Figure 3). For information on how to properly service your fork, you will need the 2001 SX Service Manual P/N: 85-3692.

**IMPORTANT:** When lubricating the fork with grease through the grease ports, it is important to note the grease is being forced between the upper and lower bushings. If the area is overfilled the force of the grease may force the upper bushing and dust seal out. You should only insert grease to the level at which stiction is no longer felt.

**IMPORTANT:** Before every ride you should:

1. Ensure that quick release skewers are properly adjusted and tight.
2. Wipe the inner legs and clean and check entire fork for any obvious damage.
3. Check the headset for proper adjustment.
4. Ensure that the front brake cable is properly routed and check brake adjustment.

## CHECKING OIL LEVEL

**IMPORTANT:** Maintaining the proper oil level in your TPC-equipped fork is critical. TPC is located in the right leg of your SX, SX 100MM and SX R forks. Not enough oil will allow foaming and reduce the performance. Too much oil will restrict travel and may cause damage to the system and create an unsafe riding condition. Finish reading this entire section prior to altering the oil level.

To check the oil level, remove the compression assembly located in the top of the right leg. Leave the left side spring stack in place to keep the fork fully extended. Use a tape measure or "dip stick" to determine the oil level. The oil level should be per the following table. (See Figure 4.)

Fork Model	OIL LEVEL		
	Maximum	Minimum	Recommended
SX E	—	—	—
SX / SX 100MM	3.75" (95 mm)	4.75" (121 mm)	4.25" (108 mm)
SX R	3.75" (95 mm)	4.75" (121 mm)	4.25" (108 mm)

*NOTE: Use Maxima SAE 5WT suspension fluid only.*

## ADJUSTING SPRING RATE

SX forks offer a wide adjustment range to suit individual riding preference and rider weight by simply changing the MCU and coil springs in the fork. Fine tuning of the spring rate can be made by rotating the adjuster knobs located on top of the left fork leg. Rotating the knob clockwise will firm the ride and add preload to the spring stack. Rotating the knob counter clockwise will soften the ride and decrease preload on the spring stack. Four full revolutions will take the adjuster from full soft to the firmest setting.

**SPRING RATE FINE TUNING: Figure 5**

### RECOMMENDED SPRING RATE FOR 2001 SX R FORK

Rider Weight	Coil Spring	MCU Spring
100-125 lbs.	(1) 5.8" 80 pound coil	(1) 2" green or 2" blue MCU
125-150 lbs.	(1) 5.8" 110 pound coil	(1) 2" green or 2" blue MCU
150-170 lbs.	(1) 5.8" 110 pound coil	(1) 2" blue MCU
170-190 lbs.	(1) 5.8" 110 pound coil	(1) 2" red or 2" yellow MCU
190+ lbs.	(1) 5.8" 140 pound coil	(1) 2" red or 2" yellow MCU

### RECOMMENDED SPRING RATE FOR 2001 SX FORK

Rider Weight	Coil Spring	MCU Spring
100-125 lbs.	(1) 3.5" 190 pound coil	(3) 2" blue and (1) 1" blue MCU
125-150 lbs.	(1) 3.5" 190 pound coil	(2) 2" blue, (1) 2" red and (1) 1" red MCU
150-170 lbs.	(1) 3.5" 190 pound coil	(3) 2" red and (1) 1" red MCU
170-190 lbs.	(1) 3.5" 190 pound coil	(2) 2" yellow, (1) 2" red and (1) 1" red MCU
190+ lbs.	(1) 3.5" 190 pound coil	(3) 2" yellow and (1) 1" yellow MCU

### RECOMMENDED SPRING RATE FOR 2001 SX 100MM FORK

Rider Weight	Coil Spring	MCU Spring
100-125 lbs.	(1) 5.8" 80 pound coil	(1) 2" blue and (1) 1.5" red MCU
125-150 lbs.	(1) 5.8" 110 pound coil	(1) 2" red and (1) 1.5" blue MCU
150-170 lbs.	(1) 5.8" 110 pound coil	(1) 2" yellow and (1) 1.5" red MCU
170-190 lbs.	(1) 5.8" 140 pound coil	(1) 2" red and (1) 1.5" yellow MCU
190+ lbs.	(1) 5.8" 140 pound coil	(1) 2" yellow and (1) 1.5" yellow MCU

*NOTE: MCU's and springs used in pre-2000 model Manitou forks are NOT interchangeable with later versions of Manitou forks. Recommended spring kits are available through your dealer.*

## ADJUSTING DAMPING

**SX R COMPRESSION DAMPING FINE TUNING: Figure 6**

To adjust the compression damping on your SX R fork, simply rotate the compression damping knob located on top of the right leg. Rotating the knob clockwise (while looking at the fork from the bottom) will increase damping, while rotating the knob counter-clockwise will reduce damping. Excessive damping (or an overly stiff spring rate) will give you a harsh ride over sharp bumps like rocky sections, but will handle large hits like G-outs well. Insufficient compression damping (or an overly soft spring rate) will cause the fork to bottom out on large hit G-outs and bob a little while climbing, but feel plush on the sharp hits. A correctly adjusted fork will perform well in all conditions.

**REBOUND DAMPING FINE TUNING: Figure 7**

To adjust the rebound damping on your SX R fork, simply rotate the rebound damping knob located on the bottom of the right leg. Rotating the knob clockwise will increase the damping, while rotating the knob counterclockwise will reduce the damping. Excessive damping (or an overly soft spring rate) will give you a harsh ride over repetitive bumps (like braking bumps) because the fork will pack up and sit too deep in the travel under normal riding conditions. Insufficient rebound damping will make the fork overly active and may even cause the fork to top out (a slight thumping noise when the fork extends completely). We suggest that you try adjusting your fork on the very active side, with minimum rebound damping. Then try it over a variety of terrain and tune in more rebound from there.

## TUNING TPC SPORT

TPC Sport is not adjustable externally, but that doesn't mean you can't vary the feel of the fork; changing the fork oil weight in your TPC Sport-equipped fork will significantly alter the damping character of the fork. The standard fork fluid for Manitou forks is 5-weight Maxima, but 2.5-weight oil will decrease damping control, while 7.5-weight will increase damping control in the TPC Sport system.

One thing to remember when changing standard fork fluid is that the increased or decreased oil weight will affect both compression and rebound damping equally. This means that while you may be slowing rebound down by say, adding heavier fork oil, you also may be adding compression damping to the point of the fork feeling harsh. The best thing to do is to experiment with different oil weights until you find that perfect setting for you.

*NOTE: Since TPC Sport uses orifices (or holes) in the compression and rebound pistons to meter the flow of oil (and thus create damping), changing the orifice sizing may seem an obvious method to tuning TPC Sport. While doing this will produce significant changes in the damping of the fork, it is not recommended. Changing the size of the damping ports risks damaging the pistons, will void the warranty on the fork and will most likely compromise the performance of the fork as well.*

Figures 8, 9, 10 & 11 are schematics of the SX E, SX, SX 100MM & SX R.

## BUSHING & SEAL DETAIL

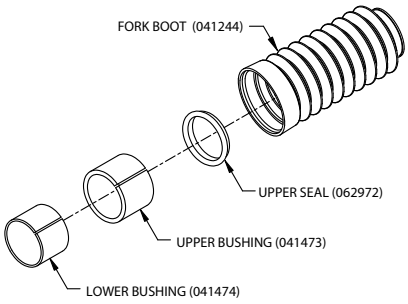

## 2001 SX FORK SCHEMATIC

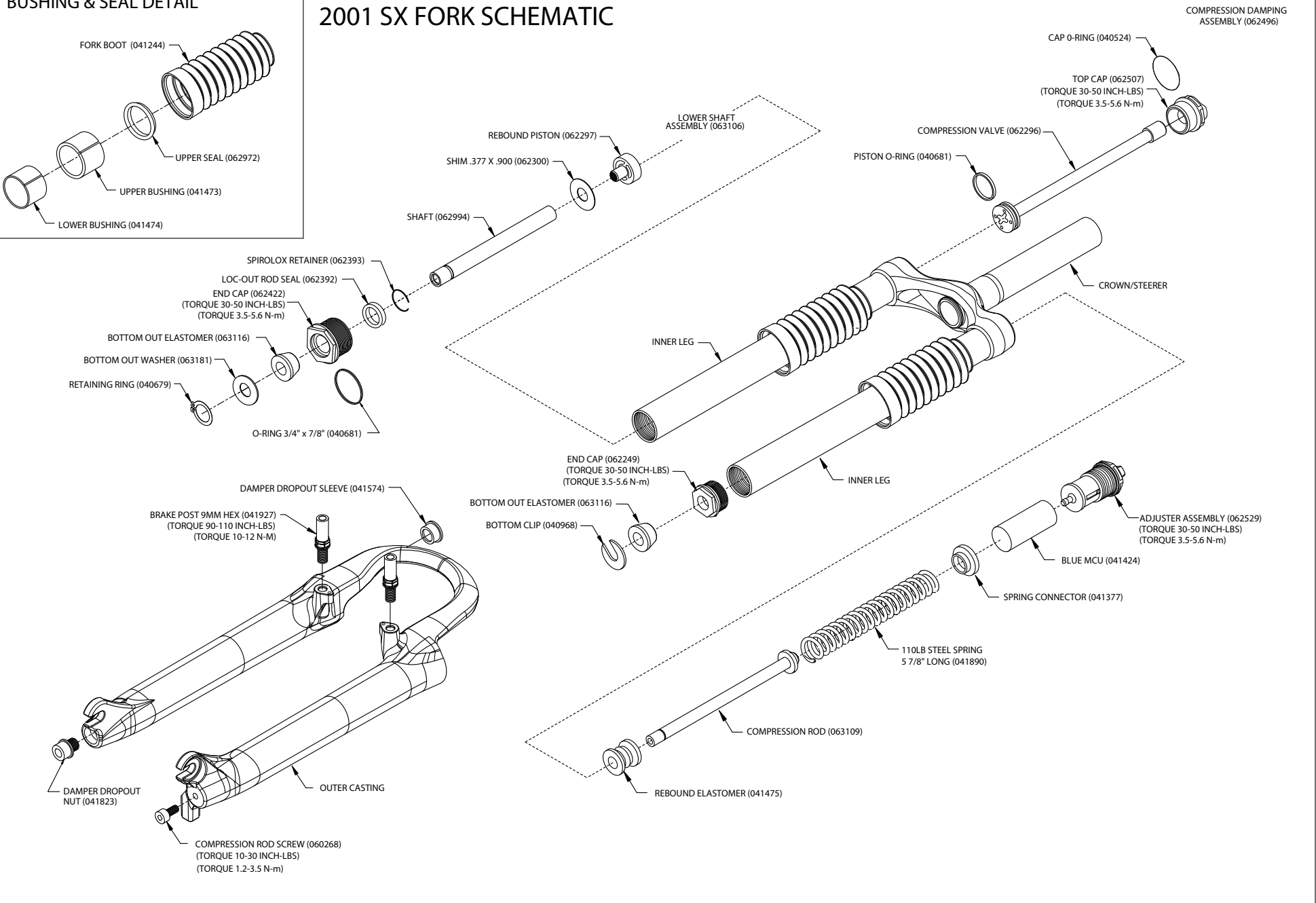

## BUSHING & SEAL DETAIL

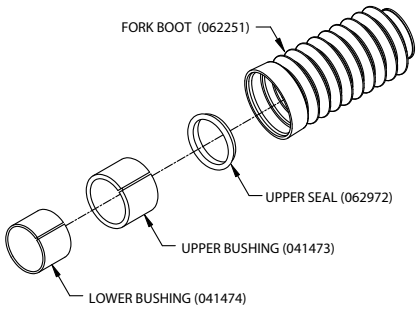

## 2001 SX 100MM FORK SCHEMATIC

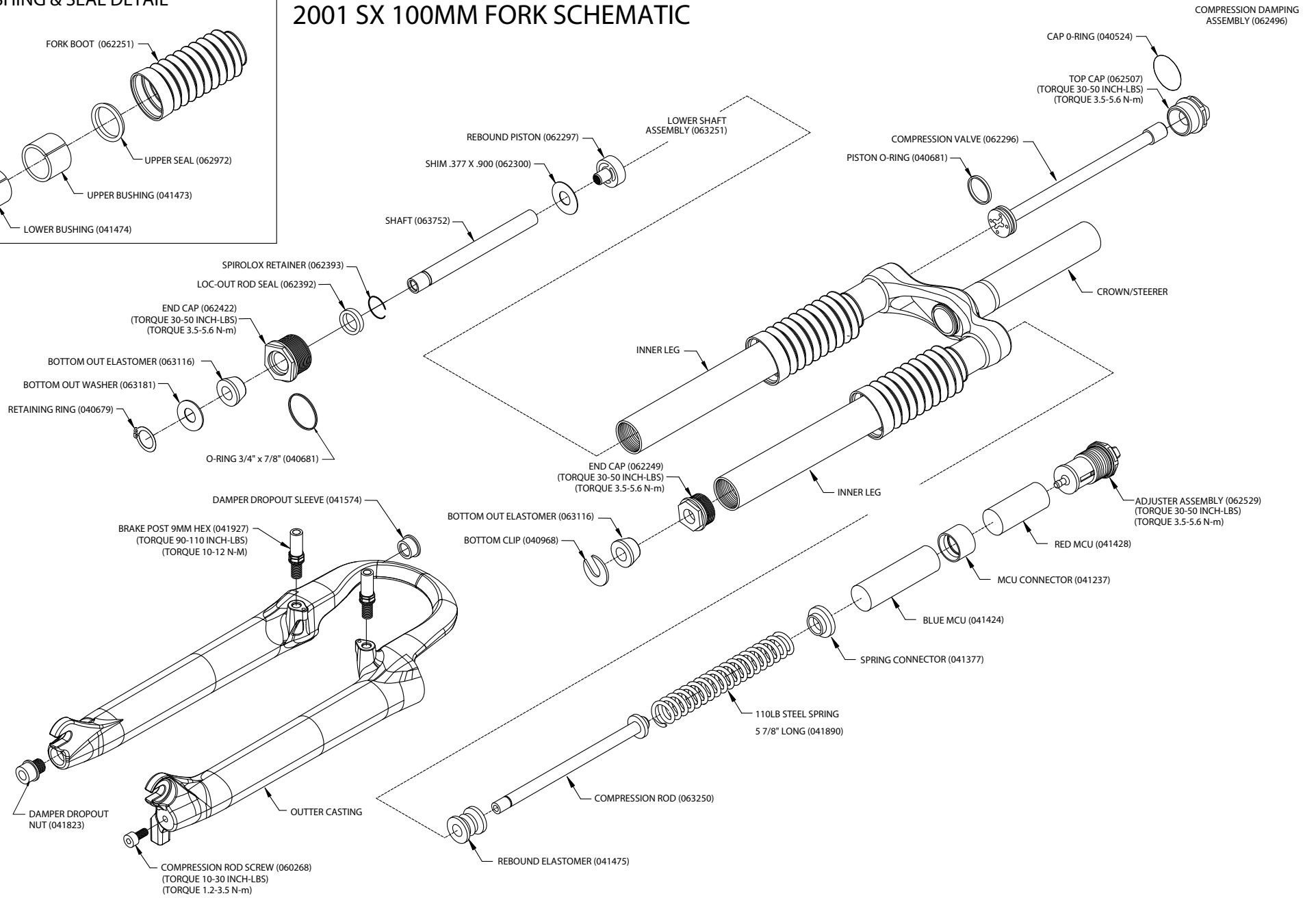

### BUSHING & SEAL DETAIL

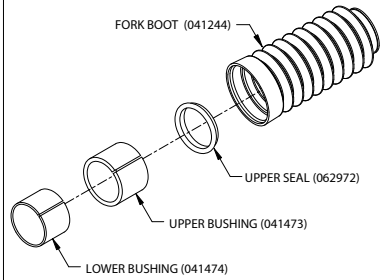

### 2001 SX E FORK SCHEMATIC

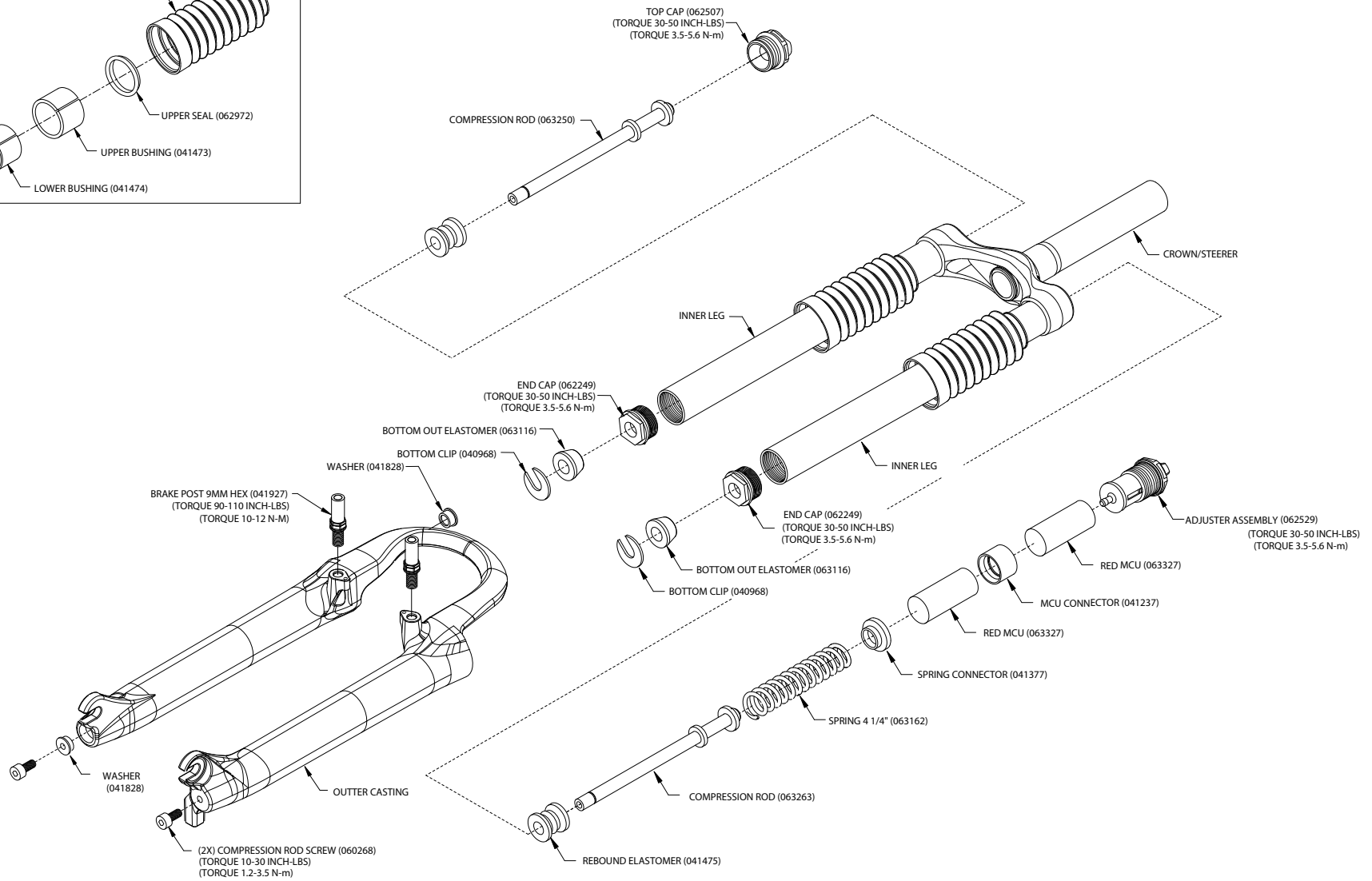

### BUSHING & SEAL DETAIL

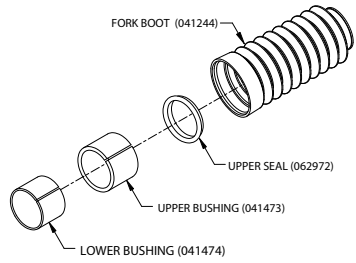

### 2001 SX R FORK SCHEMATIC

