



**1**

Race Installation

Einbau des Steuersatzringes

Instalación del anillo de rodadura

Installation du jeu de direction

Montaggio dell'anello della testa

Installatie van loopring

Instalação do canaleta

CROWN RACE  
GABELBRÜCKEN-  
STEUERSATZRING  
ANILLO DE RODADURA  
CONE DE JEU DE DIREC-  
TION  
ANELLO DELLA TESTA  
KROONLOOPRING  
CANALETE DA COROA

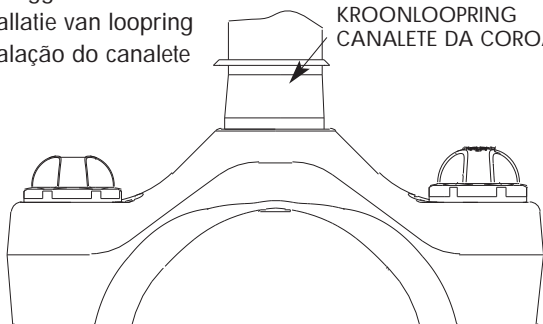

**2**

Axle and hub installation  
Einbau der Achse und Nabe  
Instalación del eje y cubo  
Installation de l'axe et du moyeu

Montaggio dell'assale e del mozzo  
Installatie van as en naaf  
Instalação do eixo e do cubo

RIGHT PINCH BOLTS  
RECHTE KLEMM-  
SCHRAUBEN  
PERNOS DE  
PRESIÓN DERECHOS  
BOULONS À SERRAGE  
DU CÔTÉ DROIT  
BULLONI DI SERRAGGIO  
DI DESTRA  
RECHTER KLEMBOUTEN  
PARAFUSOS DIREITOS  
DE APERTO

LEFT PINCH BOLTS  
LINKE KLEMMSCHRAUBEN  
PERNOS DE PRESIÓN  
IZQUIERDOS  
BOULONS À SERRAGE DU  
CÔTÉ GAUCHE

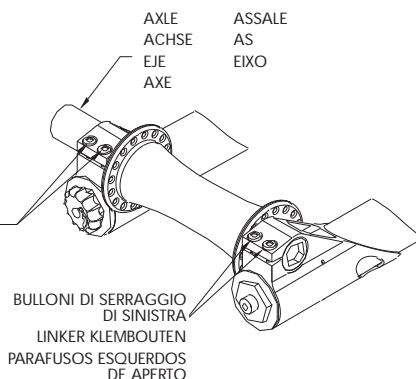

BULLONI DI SERRAGGIO  
DI SINISTRA  
LINKER KLEMBOUTEN  
PARAFUSOS ESQUERDOS  
DE APERTO

**3**

Tire clearance

Reifenabstand

Espacio libre de la cubierta

Distance arceau/pneu

Spazio libero del pneumatico

Bandspeling

Folga do pneu

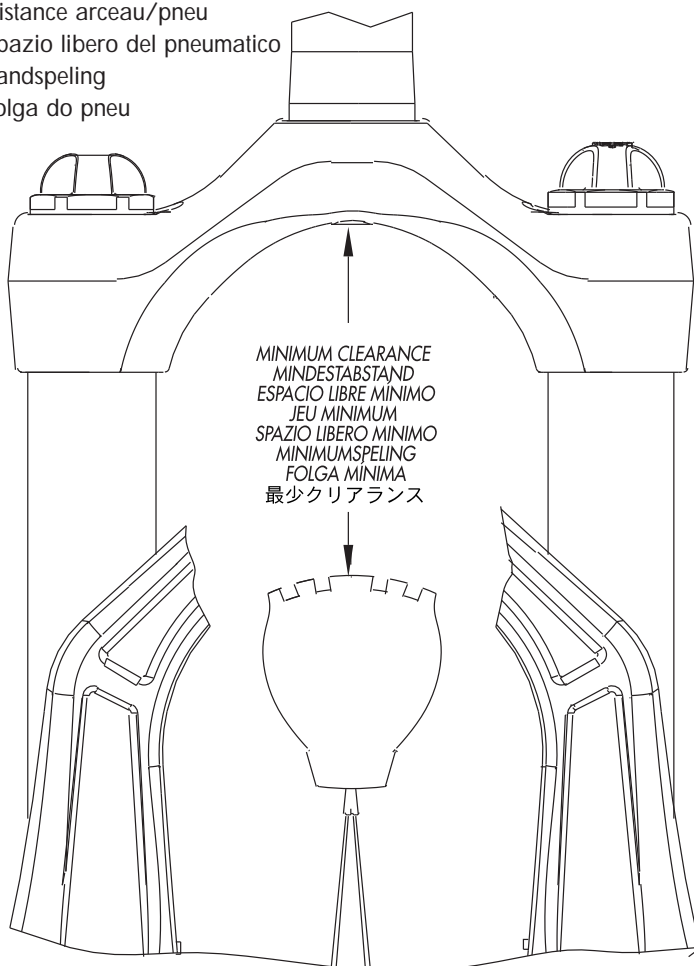

MINIMUM CLEARANCE  
MINDESTABSTAND  
ESPACIO LIBRE MÍNIMO  
JEU MINIMUM  
SPAZIO LIBERO MÍNIMO  
MINIMUMSPELING  
FOLGA MÍNIMA  
最少クリアランス

FORK MODEL  
GABELMODELL  
MODELO DE HORQUILLA  
MODELE DE FOURCHE  
MODELLO DI FORCELLA  
VORKMODEL  
MODELO DO GARFO

MINIMUM CLEARANCE  
MINDESTABSTAND  
ESPACIO LIBRE MÍNIMO  
JEU MINIMUM  
SPAZIO LIBERO MÍNIMO  
MINIMUMSPELING  
FOLGA MÍNIMA

105 mm travel forks	4.14" (105 mm)
120 mm travel forks	4.73" (120 mm)
180 mm travel forks	7.10" (180 mm)

Gabel mit 105 mm Auslenkung	105 mm
Gabel mit 120 mm Auslenkung	120 mm
Gabel mit 180 mm Auslenkung	180 mm

Horquillas con recorrido de 105 mm	105 mm
Horquillas con recorrido de 120 mm	120 mm
Horquillas con recorrido de 180 mm	180 mm

Fourches ayant une course de 105 mm	105 mm
Fourches ayant une course de 120 mm	120 mm
Fourches ayant une course de 180 mm	180 mm

Forcelle con corsa da 105 mm	105 mm
Forcelle con corsa da 120 mm	120 mm
Forcelle con corsa da 180 mm	180 mm

Loop van 105 mm	105 mm
Loop van 120 mm	120 mm
Loop van 180 mm	180 mm

Curso de 105 mm	105 mm
Curso de 120 mm	120 mm
Curso de 180 mm	180 mm

4

Microlube grease ports  
 Microlube Schmieröffnung  
 Orificio de engrasado Microlube  
 Graisseur Microlube  
 Apertura per l'ingrassaggio Microlube  
 Microlube smeergat  
 Orifício de lubrificação Microlube

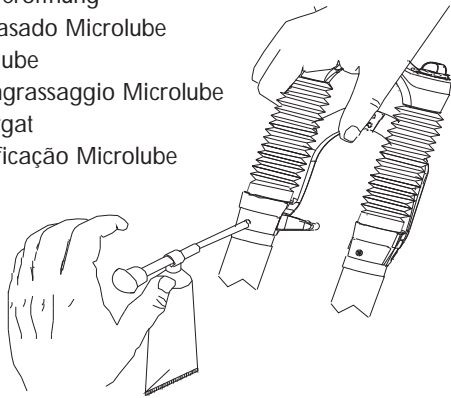

7

Fine tuning air/coil spring rate  
 Feinabstimmung der Luft-/  
 Schraubenfederrate  
 Ajuste de precisión de la  
 capacidad de resortes  
 neumáticos y helicoidales  
 Réglage du taux de raideur  
 des ressorts pneumatique/ à bobine  
 Messa a punto pneumatica/  
 della molla di compressione  
 Fijnafstelling van lucht-/springveer  
 Ajuste de precisão da taxa de  
 compressão da mola  
 pneumática/helicoidal

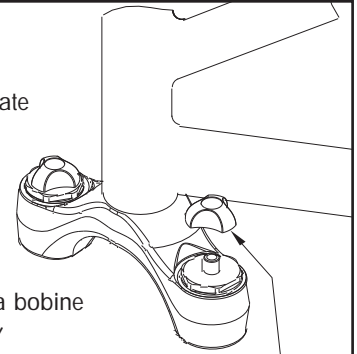

AIR CAP  
 LUFTKAPPE  
 TAPA DEL AIRE  
 CAPUCHON D'AIR  
 Cappelotto dell'aria  
 LUCHTDOP  
 TAMPA DO AR

5

Oil level  
 Ölstand  
 Nivel del aceite  
 Niveau d'huile  
 Livello dell'olio  
 Olipeil  
 Nível do óleo

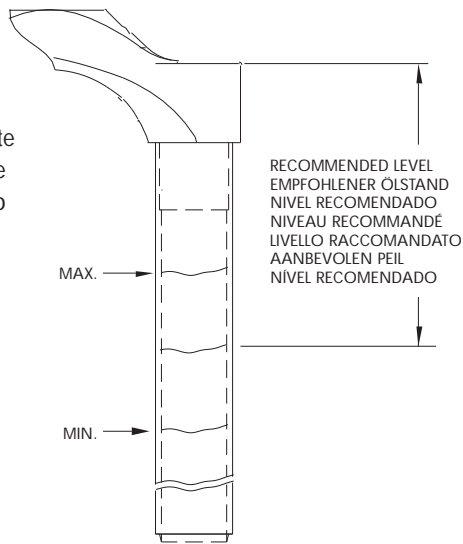

RECOMMENDED LEVEL  
 EMPFOHLENER ÖLSTAND  
 NIVEL RECOMENDADO  
 NIVEAU RECOMMANDÉ  
 LIVELLO RACCOMANDATO  
 AANBEVOLEN PEIL  
 NIVEL RECOMENDADO

8

Fine tuning compression damping  
 Feinabstimmung der  
 Druckstufendämpfung  
 Ajuste de precisión para el  
 sistema de amortiguación  
 de compresión  
 Réglages fins de  
 l'amortissement de  
 la compression  
 Messa a punto del gruppo  
 compressione di smorzamento  
 Fijnafstelling van drukdemping  
 Ajuste de precisão do  
 amortecimento de compressão

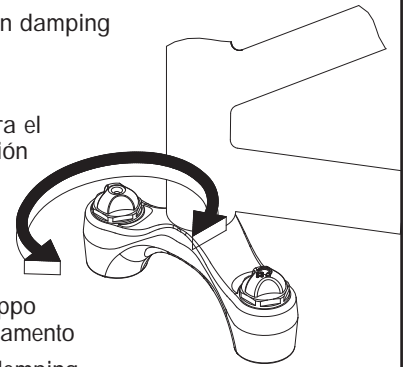

ROTATE  
 DREHEN  
 GIRAR  
 TOURNER

RUOTARE  
 DRAAIEN  
 GIRAR

9

Fine tuning rebound damping  
 Feinabstimmung der Zugstufendämpfung  
 Ajuste de precisión para la amortiguación de rebote  
 Réglages fins de l'amortissement de la détente  
 Messa a punto dello smorzamento all'estensione  
 Fijnafstelling van terugveringdemping  
 Ajuste de precisão do ressalto de amortecimento

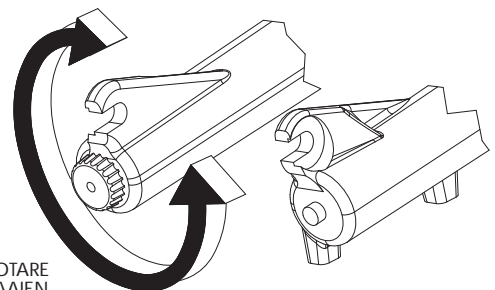

ROTATE  
 DREHEN  
 GIRAR  
 TOURNER

RUOTARE  
 DRAAIEN  
 GIRAR

6

Fine tuning compression spring  
 Feinabstimmung der Druckfeder  
 Ajustes de precisión al resorte  
 de compresión  
 Réglages fins des ressorts  
 de compression  
 Messa a punto della molla  
 di compressione  
 Fijnafstelling van drukveer  
 Mola de compressão de ajuste preciso

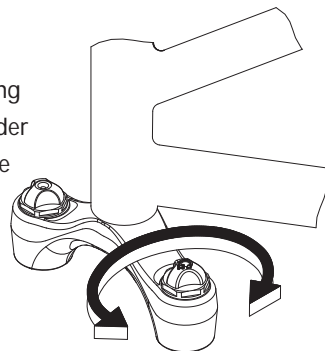

ROTATE  
 DREHEN  
 GIRAR  
 TOURNER

RUOTARE  
 DRAAIEN  
 GIRAR

## AMERICAN MADE MANITOU SUSPENSION

CONGRATULATIONS ON CHOOSING THE LATEST IN SUSPENSION TECHNOLOGY AVAILABLE, A 2001 MANITOU X-VERT BUILT IN THE USA. WITH THIS FORK INSTALLED ON YOUR BIKE, YOU'LL BE ABLE TO RIDE FASTER AND HAVE MORE FUN. SOME WORDS ON YOUR NEW X-VERT BEFORE WE BEGIN. 2001 X-VERT FORKS USE MANITOU'S PATENTED TPC PLUS (TWIN PISTON CHAMBER) SYSTEM THAT SURPASSES ALL OTHER TYPES OF OIL-DAMPED SYSTEMS IN PERFORMANCE AND DURABILITY. X-VERT FORKS ALSO USE MANITOU'S QUICK AND EASY MICROLUBE SYSTEM, WHICH ALLOWS YOU TO LUBRICATE THE FORK VIA AN EXTERNAL FITTING ON THE BACK OF THE FORK. ALL MANITOU FORKS COME EQUIPPED WITH 74MM POST-STYLE DISC BRAKE MOUNTS. THE X-VERT CARBON AND SUPERNOVA USE A 20MM OVERSIZE THROUGH-AXLE, WHICH IS COMPATIBLE WITH STANDARD DH HUBS.

This X-VERT fork is fully assembled and ready to be installed onto your bicycle. It comes equipped with a 1 1/8-inch threadless steerer tube, is available with a V-brake-style hangerless arch, or there's an optional attachable cable hanger which is available through your dealer. Manitou does not recommend retrofitting dual crown forks to older bicycle frames or frames not specially built for dual crown forks. Dual crown forks may put greater stress on older frames, so you should contact the frame manufacturer before installing this style of fork on your bike.

### 2001 X-VERT FORK LINE

X-VERT .....	105 MM TRAVEL / COIL SPRING / TPC PLUS DAMPING / SINGLE CROWN
X-VERT SUPER .....	105 MM TRAVEL / COIL SPRING / TPC PLUS DAMPING / SINGLE MRD HOLLOW CROWN
X-VERT AIR .....	105 MM TRAVEL / AIR-COIL SPRING / TPC PLUS DAMPING / SINGLE MRD HOLLOW CROWN
X-VERT SUPERNOVA...	120 MM TRAVEL / COIL SPRING / TPC PLUS DAMPING / SINGLE MRD HOLLOW CROWN / 20 MM THROUGH-AXLE
X-VERT CARBON .....	180 MM TRAVEL / COIL SPRING / TPC PLUS DAMPING / DUAL CROWN / 20 MM THROUGH-AXLE

One last note. If you lose this manual, or want to take a look at the X-VERT Service Manual or MRD Tuning Manual, head straight for the web at [www.answerproducts.com](http://www.answerproducts.com) or call (661) 257-4411 and ask for customer service.

**! GENERAL WARNING** BICYCLING IS A HAZARDOUS ACTIVITY THAT REQUIRES THAT THE RIDER STAY IN CONTROL OF HIS OR HER BICYCLE AT ALL TIMES. READING THIS MANUAL ENTIRELY AND PROPERLY MAINTAINING YOUR BICYCLE AND SUSPENSION FORK WILL REDUCE THE POSSIBILITY OF INJURY OR POSSIBLE DEATH. PRIOR TO RIDING YOUR BICYCLE, YOU SHOULD INSPECT YOUR SUSPENSION FORK TO ENSURE THAT NO DAMAGE HAS OCCURRED DURING THE COURSE OF RIDING. DO NOT RIDE YOUR BICYCLE IF THE FORK OR SHOCK SHOWS ANY SIGNS OF BENDING, CRACKING, LEAKING, OR IF IT IS MISSING ANY OF THE ORIGINALLY SUPPLIED COMPONENTS. ANY FALL FROM YOUR BICYCLE CAN RESULT IN SERIOUS INJURY OR EVEN DEATH. FOLLOWING THESE INSTRUCTIONS CAN HELP YOU REDUCE THE RISK OF BEING INJURED.

IF YOU ARE A MODERATE OR AGGRESSIVE OFF-ROAD RIDER, OR RIDE AT LEAST THREE TIMES A WEEK OVER ROUGH TERRAIN, ANSWER RECOMMENDS RETURNING YOUR SUSPENSION FORK EVERY 2 YEARS FOR A THOROUGH INSPECTION AND UPDATE. TAKE YOUR FORK TO A MANITOU AUTHORIZED DEALER WHO CAN ARRANGE FOR SHIPMENT TO ANSWER PRODUCTS, OR YOU MAY CALL ANSWER TO HAVE YOUR FORK SHIPPED DIRECTLY AT (661) 257-4411.

**IMPORTANT:** The X-VERT fork is an off-road fork, and as such, does not come with proper reflectors for on-road use. Have your dealer or mechanic install proper reflectors to meet the Consumer Product Safety Commission's (C.P.S.C.) Requirements for Bicycles if the fork is going to be used on public roads at any time. If you have questions regarding C.P.S.C. Standards or would like to purchase a reflector bracket kit (Part Number 85-3674) contact your dealer.

## CONSUMER SAFETY INFORMATION

1. Never remove or have the steerer tube or stanchions removed from the crown. The steerer tube and stanchions (inner legs) are press fit at the factory. Press fit inner legs have higher performance versus bolt-in inner legs, but can not be pressed out. Pressing them out will permanently damage the crown beyond repair and render it unsafe for any continued use.
2. Never attempt to thread a threadless steerer tube. Cutting threads will weaken the steerer tube and cause an unsafe condition. The only safe thing to do is to obtain the proper crown/steerer from your dealer, on contact Answer customer service at (661) 257-4411.
3. Any other alteration or modification to your fork should be considered unsafe. Contact Answer Technical Support prior to modifying your fork in any way for safety information.
4. Do not use the X-VERT fork if any parts are broken, bent, cracked, or you suspect may be damaged. Contact your dealer or Answer Products Technical Support at (661) 257-4411 if you have any questions concerning the integrity or condition of your fork.
5. Answer Products recommends that you periodically inspect your fork for wear and damage. Inspect the crown, inner legs, outer legs dropout and brake arch areas for cracks or damage.

## WARRANTY INFORMATION

Any Answer Products fork found by the factory to be defective in materials and/or workmanship within one year from the date of purchase will be repaired or replaced at the option of the manufacturer, free of charge, when received at the factory, freight prepaid. This warranty does not cover breakage, bending, or damage that may result from crashes or falls. This warranty does not cover any fork that has been subject to misuse or whose serial number has been altered, defaced or removed. This warranty does not cover paint damage. Any modifications made by the user will render the warranty null and void. This warranty is expressly in lieu of all other warranties, and any implied are limited in duration to the same duration as the expressed warranty herein. Answer Products shall not be liable for any incidental or consequential damages.

If for any reason warranty work is necessary, return the fork and original purchase receipt to the place of purchase. In the USA, dealers should call Answer Products for a return authorization number (RA#) at (661) 257-4411. At that time, instructions for repair, return, or replacement shall be given. Customers in countries other than USA should contact their dealer or local distributor.

## INSTALLATION INSTRUCTIONS

Ensure that the proper steerer tube has been delivered on your X-VERT first. The steerer tube may need to be cut to length to fit your bicycle head tube. If you are not familiar with this procedure, or do not have the proper tools to cut the steerer tube, it is recommended that you seek a dealer with a qualified bicycle mechanic to perform installation.

**! WARNING** THE STEERER TUBE AND STANCHIONS (INNER LEGS) ARE A ONE-TIME PRECISION PRESS FIT AT THE FACTORY AND CANNOT BE REMOVED FROM THE CROWN. REPLACEMENT OF THE ENTIRE CROWN/STEERER ASSEMBLY MUST BE DONE TO CHANGE STEERER TUBE LENGTHS OR DIAMETERS. REMOVING AND REPLACING THE STEERER TUBE OR STANCHIONS WILL RESULT IN AN UNSAFE CONDITION AND SHOULD NEVER BE DONE.

### FORK INSTALLATION

1. Remove the old fork from your bicycle.
2. Measure and cut the steerer tube to fit your bicycle head tube. You can use your old fork as a guide to how long you should cut the steerer tube to.
3. Remove the headset crown race from the old fork and press onto X-VERT steerer until the race is seated over the crown (Figure 1).
4. Clean and grease the headset bearings and races.
5. Install the lower bearings (if applicable) on fork crown race.
6. Insert the steerer tube into the head tube of the frame.
7. Install the upper bearings, stem spacers, and stem.
8. Install the stem cap and bolt. Tighten the bolt to headset manufacturer's specifications.
9. Install the handlebars to desired height and the torque stem pinch screws or stem clamping system to manufacturer's specifications.
10. Install the brakes and adjust per the manufacturer's instructions.
11. Position the X-VERT CARBON (dual crown fork) steering stop bumpers to prevent frame damage.
12. For all X-VERTS except X-VERT CARBON and X-VERT SUPERNOVA, adjust the front wheel quick release to clear the 0.275" (7 mm) thick secondary catch dropout. The quick release must be tightened after it is properly seated into the dropout counter bores to manufacturer's specifications. Ensure that there is adequate thread engagement (4 or more threads with the release adjusted to lock).
13. For the X-VERT CARBON and X-VERT SUPERNOVA, lightly pinch the thread axle sleeve in the left dropout. Install the through-axle and hub. Tighten the axle until it bottoms 60 to 90 in-lbs. (6.8-10.2 Nm). Push the fork up and down to find the center position and torque the right dropout pinch bolts to 30 to 50 in-lbs. (3.4-5.6 Nm). See Figure 2.
14. Install the brake cable per manufacturer's instructions:

NOTE: 2001 X-VERT, X-VERT AIR, and X-VERT SUPER forks are equipped with a secondary catch dropout. The X-VERT CARBON and X-VERT SUPERNOVA forks are equipped with oversize 20mm through-axes that are compatible with standard DH hubs.

**! WARNING** WHEN INSTALLING THE WHEEL OR A NEW TIRE, CHECK TO MAKE SURE THE FORK ACHIEVES MINIMUM TIRE CLEARANCE. MEASURE FROM THE HIGHEST POINT ON THE TIRE TO THE BOTTOM OF THE CROWN. THE MINIMUM CLEARANCE ALLOWED IS:  
 4.25" (108 MM) FOR 105 MM TRAVEL FORKS  
 4.84" (123 MM) FOR 120 MM TRAVEL FORKS  
 7.20" (183 MM) FOR 180 MM TRAVEL FORKS  
 ANY CLEARANCE LESS THAN THIS CAN RESULT IN SERIOUS INJURY OR DEATH. FIGURE 3

**IMPORTANT:** The X-VERT should not be used if any parts appear to be or are damaged. Contact your local dealer or Answer Products for replacement parts.

## MAINTENANCE

**IMPORTANT:** Use of fork boots is required to keep your X-VERT fork performing well and the warranty in effect. Use of this fork without boots will shorten the life of the fork, decrease the time between maintenance intervals, reduce the performance and void the warranty. The only exception is a fork that is sold by Answer from the factory without boots.

Your X-VERT fork requires periodic maintenance, cleaning and inspection. This is because moisture and contamination may build up inside the fork depending on the severity of riding conditions. To maintain top performance, it is recommended that the fork be periodically disassembled, cleaned, dried and re-greased using the Microlube grease ports located on the back of each outer leg. For information on how to properly service your fork, you will need the 2001 X-VERT Service Manual P/N: 85-3693, which can be found on the web at [www.answerproducts.com](http://www.answerproducts.com).

**IMPORTANT:** When lubricating the fork with grease through the grease ports, it is important to note the grease is being forced between the upper and lower bushings. If the area is overfilled the force of the grease may force the upper bushing and dust seal out. You should only insert grease to the level at which stiction is no longer felt. (Figure 4)

**IMPORTANT:** Before every ride you should:

1. Ensure that quick release skewers are properly adjusted and tight. If it is a through-axle style fork, ensure that the pinch bolts are tight on the axle.
2. Wipe the inner legs and clean and check entire fork for any obvious damage.
3. Check the headset for proper adjustment.
4. Ensure that the front brake cable is properly routed and check brake adjustment.

## CHECKING OIL LEVEL

**IMPORTANT:** Maintaining the proper oil level in your TPC Plus equipped fork is critical. TPC Plus is located in the right leg of your X-VERT fork. Not enough oil will allow foaming and reduce the performance. Too much oil will restrict travel and may cause damage to the system and create an unsafe riding condition. Finish reading this entire section prior to altering the oil level.

To check the oil level, remove the compression assembly located in the top of the right leg. Leave the left side spring stack in place to keep the fork fully extended. Use a tape measure or "dip stick" to determine the oil level. The oil level should be per the following table. (See Figure 5.)

Fork Model	OIL LEVEL		
	Recommended	Maximum	Minimum
X-VERT	3.75" (95 MM)	3.50" (89 MM)	4.00" (102 MM)
X-VERT AIR	3.75" (95 MM)	3.50" (89 MM)	4.00" (102 MM)
X-VERT SUPER	3.75" (95 MM)	3.50" (89 MM)	4.00" (102 MM)
X-VERT SUPERNOVA	4.50" (114 MM)	4.25" (108 MM)	4.75" (120 MM)
X-VERT CARBON	8.00" (203 MM)	7.00" (178 MM)	9.00" (228 MM)

NOTE: Use Maxima SAE 5WT suspension fork oil only.

## ADJUSTING SPRING RATE

**COMPRESSION SPRING FINE TUNING: Figure 6**

X-VERT forks offer a wide adjustment range to suit individual riding preference and rider weight by simply changing the MCU and coil springs in the fork. Fine tuning of the spring rate can be made by rotating the preload adjuster knobs located on top of the left fork leg. Rotating the knob clockwise will firm the ride and add preload to the spring stack. Rotating the knob counter clockwise will soften the ride and decrease preload on the spring stack. Four full revolutions will take the adjuster from full soft to the firmest setting.

**AIR/COIL SPRING RATE FINE TUNING: Figure 7**

The 2001 X-VERT AIR forks use a combination of air and a coil spring. The air spring is adjustable via a Schraeder valve located on top of the left leg. The coil spring can also be switched with stiffer or softer versions to accommodate for different rider styles and terrain. There's also a coil negative spring, (but it is available in one rate only) and is designed to be preloaded automatically as the positive air spring pressure is increased (in other words, you don't need to do anything to tune it).

The air/coil system is both lightweight and produces a supple but progressive spring curve because of the use of two spring materials. The spring system in action functions like this: When the fork compresses, the coil compresses first. This is because the coil has a very low breakaway threshold (it moves with just one pound of pressure applied) and thus provides initial suppleness with the fork. The negative spring also helps provide initial suppleness because it helps actuate the air spring (a negative spring works to pull the fork together, where a positive spring is keeping the fork extended). In the middle portion of the travel, the fork transitions from the coil to the air spring. Near the end of the fork's travel, the air spring's progressive nature provides resistance to bottoming.

**Recommended Spring Rate for 2001 X-VERT AIR Forks**

Rider Weight	Air Spring	Coil Spring
under 115 lbs.	80 psi +/- 5 psi	(1) 3" blue 60 pound coil
115-145 lbs.	100 psi +/- 5 psi	(1) 3" blue 60 pound coil
145-175 lbs.	120 psi +/- 5 psi	(1) 3" red 90 pound coil
175-205 lbs.	140 psi +/- 5 psi	(1) 3" red 90 pound coil
205-230 lbs.	160 psi +/- 5 psi	(1) 3" yellow 120 pound coil
230+ lbs.	180 psi +/- 5 psi	(1) 3" yellow 120 pound coil

**Recommended Spring Rate for 2001 X-VERT and X-VERT SUPER**

Rider Weight	Coil Spring	MCU Spring
100-125 lbs.	(1) 5.8" 80 pound coil	(2) 2" blue MCU
125-150 lbs.	(1) 5.8" 80 pound coil	(1) 2" red MCU, (1) 2" blue MCU
150-170 lbs.	(1) 5.8" 110 pound coil	(2) 2" red MCU
170-190 lbs.	(1) 5.8" 110 pound coil	(1) 2" red MCU, (1) 2" yellow MCU
190+ lbs.	(1) 5.8" 140 pound coil	(1) 2" red MCU, (1) 2" yellow MCU

**Recommended Spring Rate for 2001 X-VERT CARBON**

Rider Weight	Coil Spring	MCU Spring
100-125 lbs.	(2) 8" 60 pound coil	(1) 2" blue MCU
125-150 lbs.	(1) 8" 80 pound coil, (1) 8" 60 pound coil	(1) 2" blue MCU
150-170 lbs.	(2) 8" 80 pound coil	(1) 2" red MCU
170-190 lbs.	(1) 8" 80 pound coil, (1) 8" 110 pound coil	(1) 2" red MCU
190+ lbs.	(2) 8" 110 pound coil	(1) 2" yellow MCU

**Recommended Spring Rate for 2001 X-VERT SUPERNOVA**

Rider Weight	Coil Spring	MCU Spring
100-125 lbs.	(1) 8" 80 pound coil	(1) 2" red MCU, (2) 2" blue MCU
125-150 lbs.	(1) 8" 80 pound coil	(2) 2" red MCU, (1) 2" blue MCU
150-170 lbs.	(1) 8" 100 pound coil	(2) 2" red MCU, (1) 2" blue MCU
170-190 lbs.	(1) 8" 120 pound coil	(3) 2" red MCU
190+ lbs.	(1) 8" 140 pound coil	(2) 2" red MCU, (1) 2" yellow MCU

NOTE: MCU's and springs used in pre-2000 model Manitou forks are NOT interchangeable with later versions of Manitou forks. Recommended spring kits are available through your dealer.

## TPC PLUS

TPC Plus is based on the standard TPC damper, except taken to the next level. As a result, to understand how TPC Plus works, we'll explain how standard TPC works. TPC consists of two pistons: one for compression (top) and one for rebound (bottom). As the bottom (or rebound) shaft enters the inner leg (as the fork is compressed), it displaces fork fluid up and forces it through the compression valves. The compression valves control or damps this oil flow, allowing controlling the fork's reaction to bumps. As the shaft returns to its original position, the fluid moves likewise through the rebound piston to provide damping. Each circuit, compression and rebound, has a blow by valve to allow the oil to bypass the valving when the fork is travelling the opposite direction.

Like TPC, TPC Plus is based off of the same principle, but with one thing added. TPC Plus uses a position-activated damping compression piston in addition to the static compression piston. The upper piston on the compression side is the static piston and the lower piston (not to be confused with the rebound damping piston) is the position-activated piston. As the fork compresses initially, the position-activated piston (or lower piston) moves, compressing the spring located between it and the upper piston. During the phase when the lower piston is moving, it does not provide compression damping. Rather the static piston above it provides compression damping to the fork. The static piston provides 100 percent of the fork's initial damping. But as the fork compresses further, the lower piston reaches a stop and begins to assist the upper piston by adding a 50 percent increase in compression damping.

The result of all this is a super-active ride initially (because you only have a small amount of compression damping provided by the static piston), but with controlled brake dive and bottoming (because once the fork compresses further and the position-activated piston stops, it provides additional compression damping). It's also one of the most sophisticated damping systems for suspension available today.

## ADJUSTING DAMPING

**COMPRESSION DAMPING FINE TUNING: Figure 8**

To adjust the compression damping on your X-VERT fork, simply rotate the compression damping knob located on top of the right leg. Rotating the knob clockwise will increase damping, while rotating the knob counterclockwise will reduce damping. Excessive damping (or an overly stiff spring rate) will give you a harsh ride over sharp bumps like rocky sections, but will handle large hits like G-outs well. Insufficient compression damping (or an overly soft spring rate) will cause the fork to bottom out on large hit G-outs and bob a little while climbing, but feel plush on the sharp hits. A correctly adjusted fork will perform well in all conditions.

**REBOUND DAMPING FINE TUNING: Figure 9**

To adjust the rebound damping on your X-VERT fork, simply rotate the rebound damping knob located on the bottom of the right leg. Rotating the knob clockwise will increase the damping, while rotating the knob counterclockwise will reduce the damping. Excessive damping (or an overly soft spring rate) will give you a harsh ride over repetitive bumps (like braking bumps) because the fork will pack up and sit too deep in the travel under normal riding conditions. Insufficient rebound damping will make the fork overly active and may even cause the fork to top out (a slight thumping noise when the fork extends completely). We suggest that you try adjusting your fork on the very active side, with minimum rebound damping. Then try it over a variety of terrain and tune in more rebound from there.

Figures 10, 11, 12, 13 and 14 are schematics of the X-VERT, X-VERT AIR, X-VERT SUPER, X-VERT SUPERNOVA, and X-VERT CARBON fork models.



## BUSHING & SEAL DETAIL

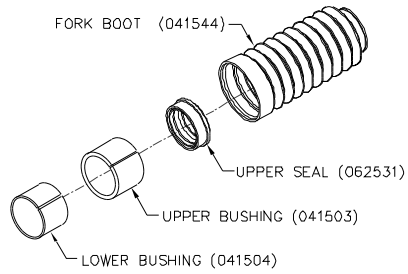

## 2001 X-VERT AIR FORK SCHEMATIC

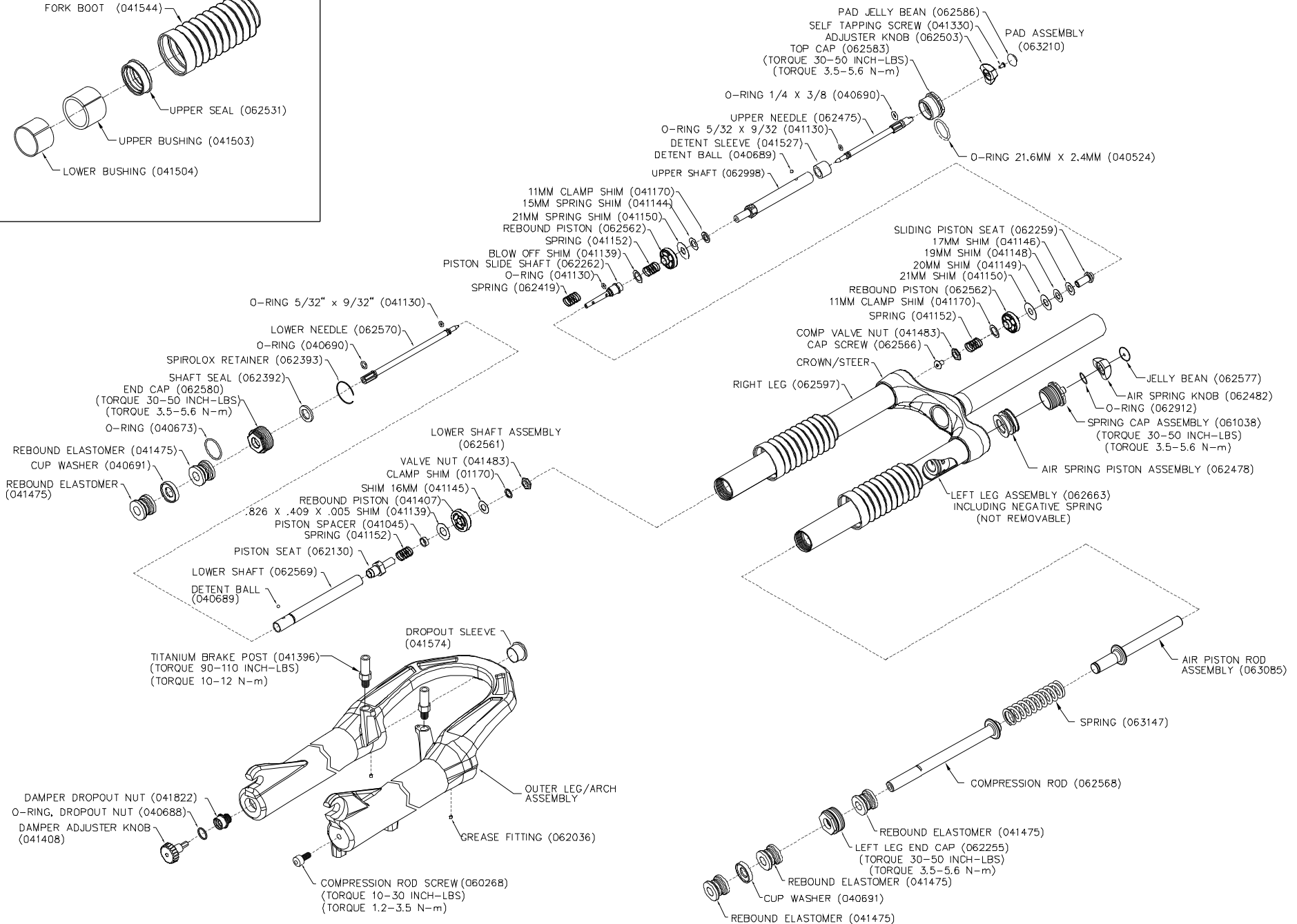

BUSHING & SEAL DETAIL

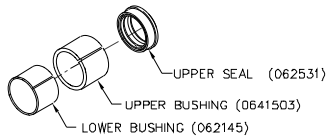

2001 X-VERT CARBON SMALL & LARGE

LOWER SHAFT ASSEMBLY (062509)

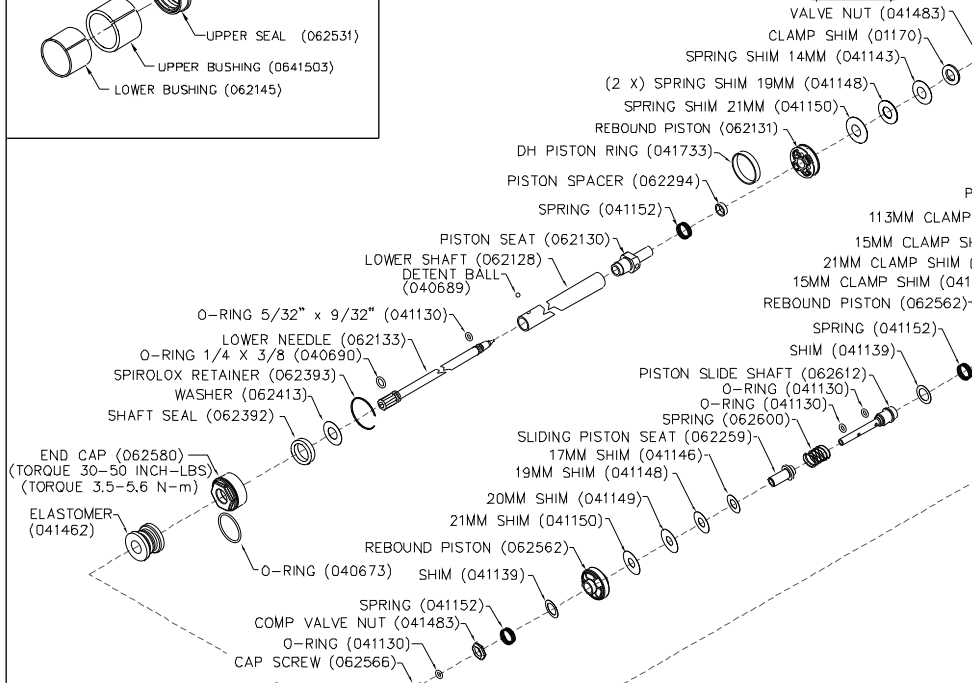

PAD ASSEMBLY (062611)

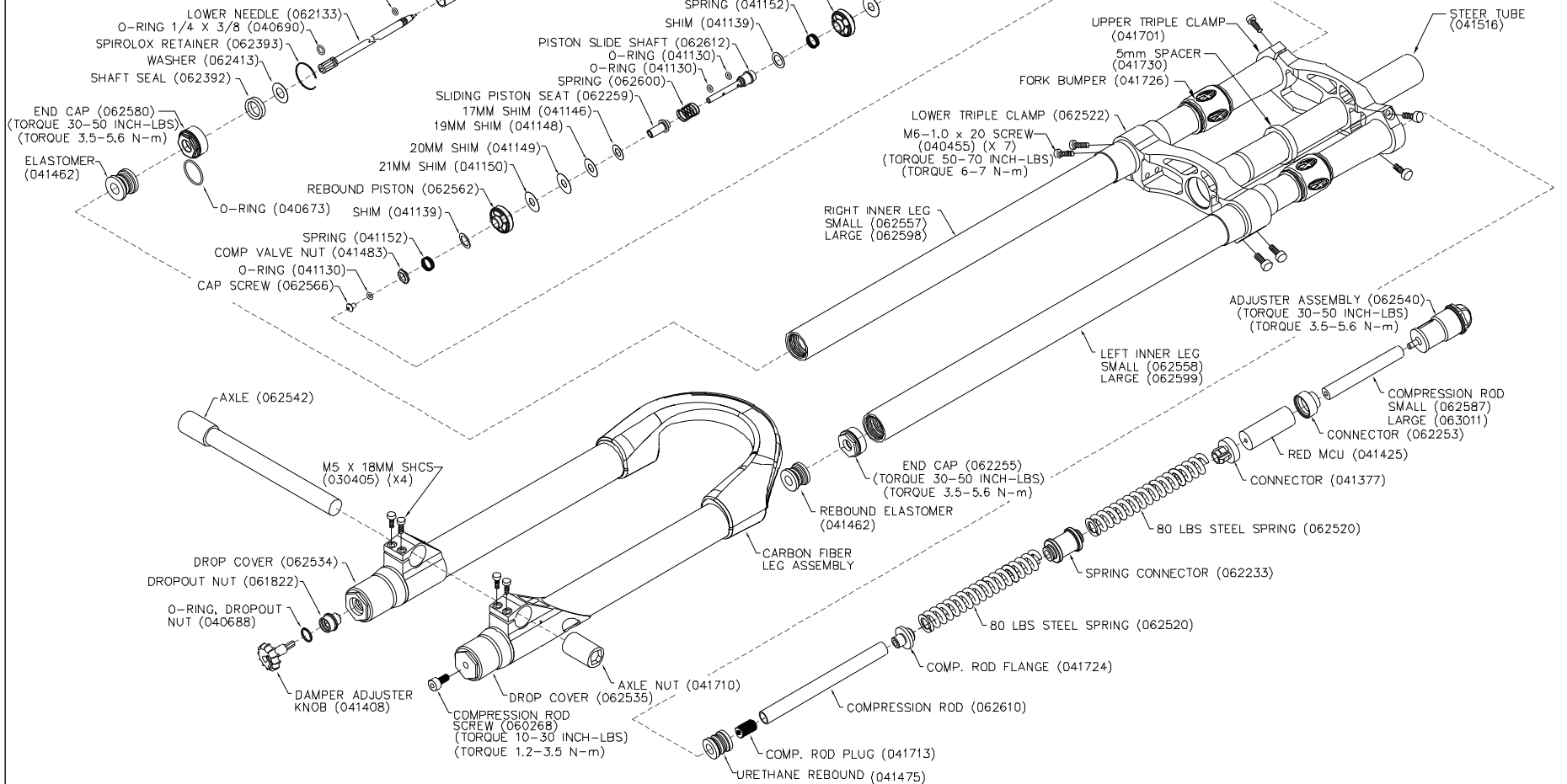
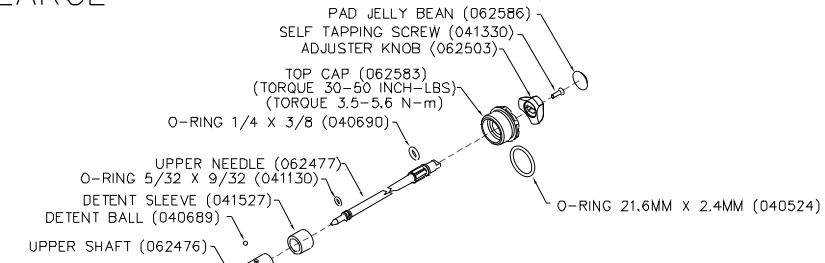

### BUSHING & SEAL DETAIL

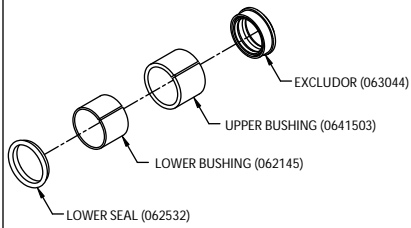

### 2001 X-VERT SUPERNOVA FORK SCHEMATIC

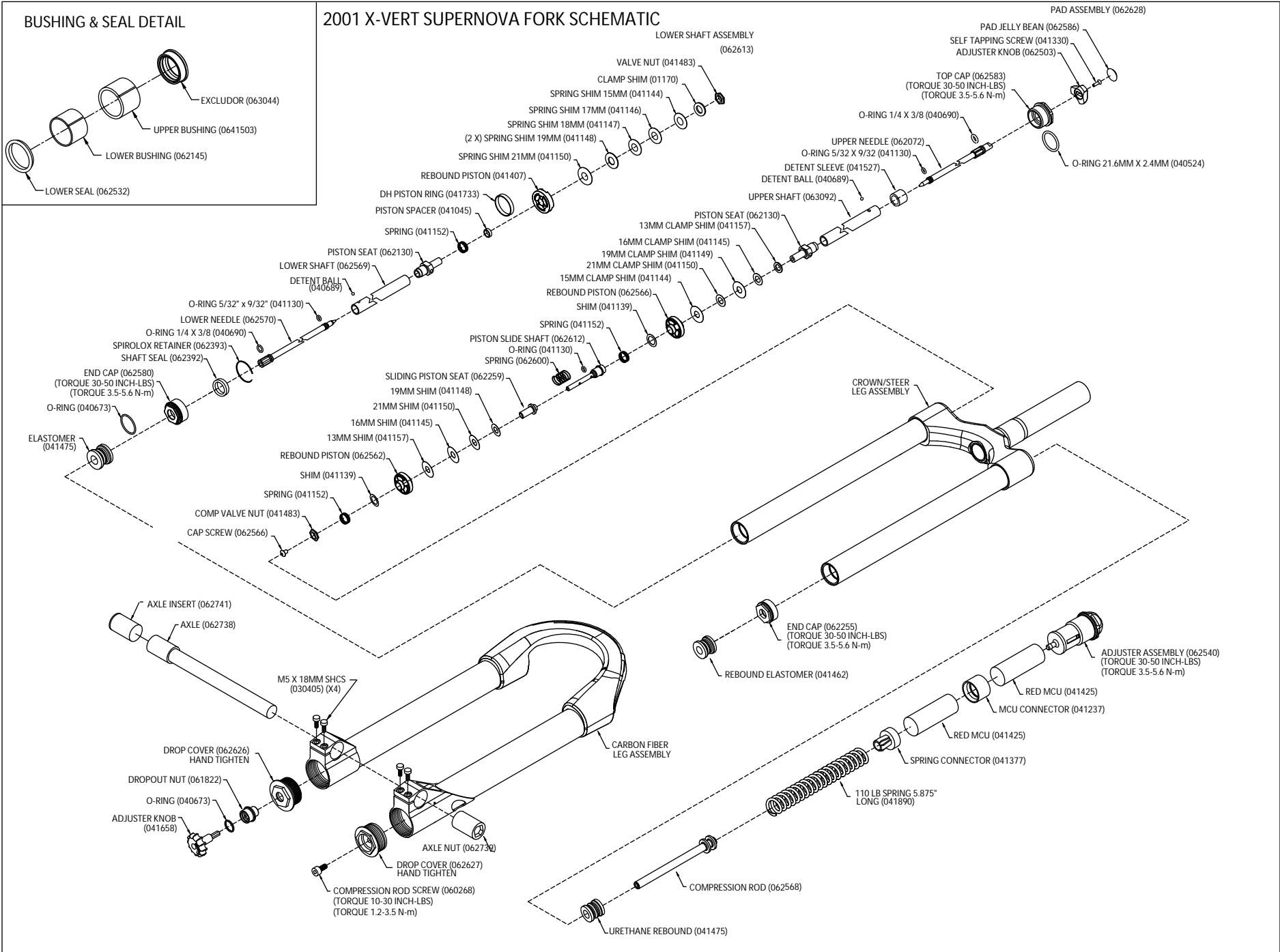

### BUSHING & SEAL DETAIL

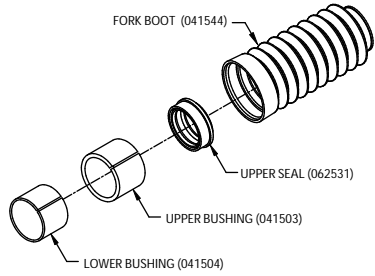

### 2001 X-VERT SUPER FORK SCHEMATIC

