

General Safety Information

⚠ WARNING

- Check that the wheels are fastened securely before riding the bicycle. If the wheels are loose in any way, they may come off the bicycle and serious injury may result.
- Obtain, read and carefully service instructions when installing parts. A loose, worn, or damaged parts may cause injury to the rider. We strongly recommend that only genuine Shimano replacement parts be used.
- Read these Technical Service Instructions carefully, and keep them in a safe place for later reference.

Note

- Do not use the CS-HG70-9 in any combination other than with the CN-HG73, CN-HG93, CN-7701. Other chains cannot be used as the sizes do not match.
- Always be sure to use the sprocket set bearing the same group marks. Never use in combination with a sprocket bearing a different group mark.
- If the wheel becomes stiff and difficult to turn, you should lubricate it with grease.
- Do not apply any lubricant to the inside of the hub, otherwise the grease will come out.
- You should periodically wash the sprockets in a neutral detergent and then lubricate them again. In addition, cleaning the chain with neutral detergent and lubricating it can be a effective way of extending the useful life of the sprockets and the chain.
- If the chain keeps coming off the sprockets during use, replace the sprockets and the chain.
- Parts are not guaranteed against natural wear or deterioration resulting from normal use.
- For maximum performance we highly recommend Shimano lubricants and maintenance products.

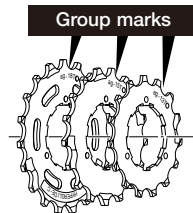

Technical Service Instructions

SI-32X0D

FH-5501 / FH-5500

Freehub

Specifications

Freehub

Model No.	FH-5501 / FH-5500
Gears	9
No. of spoke holes	32 / 36
Overlock nut dimensions	130 mm

SHIMANO

SHIMANO AMERICAN CORPORATION
One Holland, Irvine, California 92618, U.S.A. Phone: +1-949-951-5003





SHIMANO EUROPE HOLDING B.V.
Industrieweg 24, 8071 CT Nunspeet, The Netherlands Phone: +31-341-272222

SHIMANO INC.
3-77 Oimatsu-cho, Sakai, Osaka 590-8577, Japan

Please note: specifications are subject to change for improvement without notice. (English)
© Apr. 2003 by Shimano Inc. XBC SZK Printed in Japan

Cassette sprocket

Sprockets marked by  are secured.

Model No.	CS-HG70-9	
Sprocket tooth configuration	12T - 23T	12T, 13T, 14T, 15T,  16T, 17T, 19T, 21T, 23T
	12T - 25T	12T, 13T, 14T, 15T,  17T, 19T, 21T, 23T, 25T
	13T - 23T	13T, 14T, 15T,  16T, 17T, 18T, 19T, 21T, 23T
	13T - 25T	13T, 14T, 15T,  16T, 17T, 19T, 21T, 23T, 25T

Installation of the HG sprockets

For each sprocket, the surface that has the group mark should face outward and be positioned so that the wide parts of the gear projections on each sprocket and the A part (where the groove width is wide) of the freewheel body are aligned.

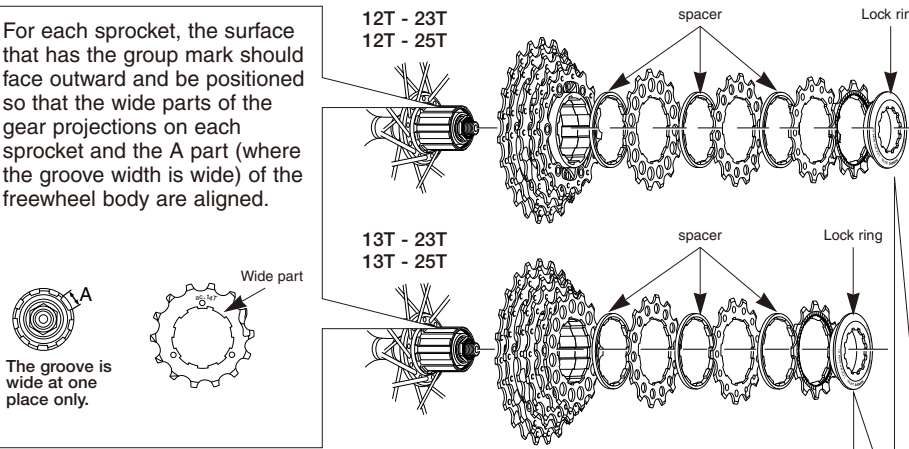

- For installation of the HG sprockets, use the special tool (TL-HG16) to tighten the lock ring.
- To replace the HG sprockets, use the special tool (TL-HG16) and TL-SR20 to remove the lock ring.

Tightening torque:
30 - 50 N·m
{261 - 434 in. lbs.}

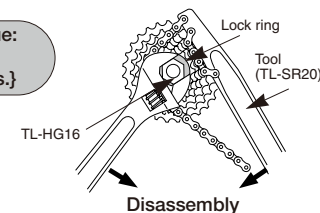

Replacement of the freewheel body

After removing the hub axle, remove the freewheel body fixing bolt (inside the freewheel body), and then replace the freewheel body.

Note:

Do not attempt to disassemble the freewheel body, because it may result in a malfunction.

Tightening torque:
35 - 50 N·m
{305 - 434 in. lbs.}

