



## General Safety Information

SI-34R0B

### **⚠ WARNING** – To avoid serious injuries:

- When securing the brake arm to the frame, be sure to securely tighten the clip screw and clip nut to the specified tightening torque. Use lock nuts with nylon inserts (self-locking nuts) for the clip nut. It is recommended that standard Shimano parts be used for the clip screw, clip nut and brake arm clip. If the clip nut comes off the brake arm, or if the clip screw or brake arm clip becomes damaged, the brake arm may rotate on the chainstay and cause the handlebars to jerk suddenly, or the bicycle wheel may lock and the bicycle may fall over, causing serious injury.
- When installing the hub to the frame, be sure to install the correct non-turn washers to the left and right sides, and securely tighten the hub nuts to the specified torques. If the non-turn washers are installed to one side only, or if the hub nuts are not tightened sufficiently, the non-turn washer may fall out, which could cause the hub axle to rotate and the cassette joint to turn. This may then cause the handlebars to be accidentally pulled by the shifting cable, and an extremely serious accident could result.
- Obtain and read the service instructions carefully prior to installing the parts. Loose, worn, or damaged parts may cause serious injury to the rider. We strongly recommend only using genuine Shimano replacement parts.
- Check that the wheels are fastened securely before riding the bicycle. If the wheels are loose in any way, they may come off the bicycle and serious injury may result.
- Read these Technical Service Instructions carefully, and keep them in a safe place for later reference.

### **NOTE:**

- You can shift gears while pedaling, but on rare occasions the pawls and ratchet inside the hub may produce some noise afterwards as part of normal gear shifting operation.
- The CJ-8S20 cassette joint should only be used with sprockets from 16T to 23T.
- If the wheel becomes stiff and difficult to turn, you should lubricate it with grease.
- Do not apply any grease to the inside of the hub, otherwise the grease will come out again.
- You should periodically wash the sprockets in a neutral detergent and then lubricate them again. In addition, cleaning the chain with neutral detergent and lubricating it can be an effective way of extending the useful life of the sprockets and the chain.
- If the chain keeps coming off the sprockets during use, replace the sprockets and the chain.
- Parts are not guaranteed against natural wear or deterioration resulting from normal use.
- For maximum performance we highly recommend Shimano lubricants and maintenance products.
- For any questions regarding methods of handling or adjustment, please contact the place of purchase.

**SG-8R20**  
**SG-8R25**  
**CJ-8S20**

Inter-8 Hub

Cassette joint

## Technical Service Instructions

**INTER8**

Be sure to read these service instructions in conjunction with the service instructions for the Inter-M Brake and the Inter-8 shifting lever before use.

### Installation of the cassette joint to the hub

1. Install the driver cap to the driver on the right side of the hub body.

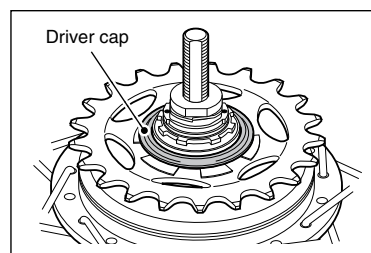
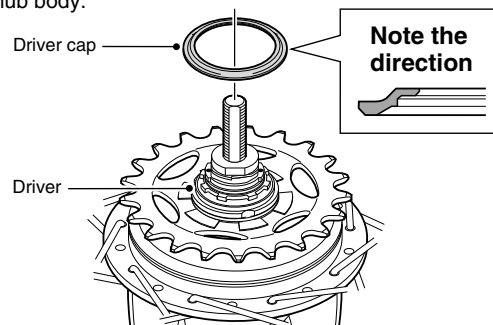

2. Turn the cassette joint pulley in the direction of the arrow in the illustration to align the red ● marks on the pulley and the bracket. With the cassette joint in this condition, install it so that the red ● mark on the cassette joint is aligned with the red ● mark on the right side of the hub body.

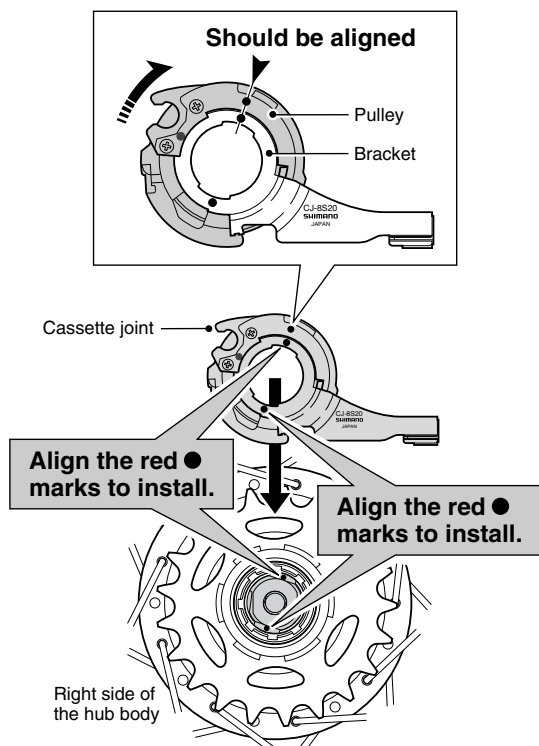

3. Secure the cassette joint to the hub with the cassette joint fixing ring. When installing the cassette joint fixing ring, align the yellow ● mark with the yellow ● mark on the cassette joint pulley, and then turn the cassette joint fixing ring 45° clockwise.

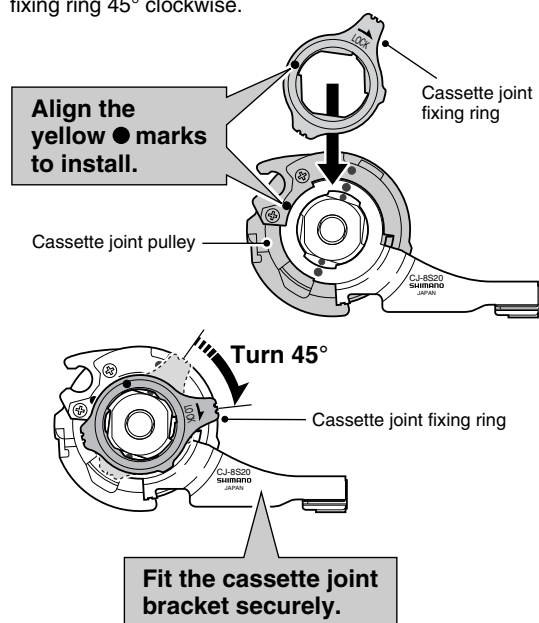

## Installation of the hub to the frame

1. Mount the chain on the sprocket, and then set the hub axle into the fork ends.

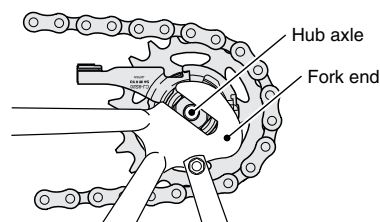

2. Place the non-turn washers onto the right side and left side of the hub axle. At this time, turn the cassette joint so that the projecting parts of the non-turn washers fit into the grooves of the fork ends. If this is done, the cassette joint can be installed so that it is almost parallel to the chainstay.

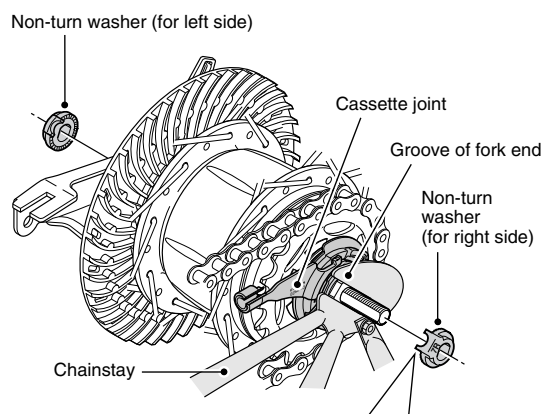

- Different types of left and right non-turn washers are available for use with standard and reversed fork ends. Use whichever non-turn washers are suitable.

Fork end	Non-turn washer		Size
	Mark/Color		
	Right	Left	
Standard	5R/Yellow	5L/Brown	$\theta \leq 20^\circ$
	7R/Black	7L/Gray	$\theta \leq 38^\circ$
Reversed	6R/Silver	6L/White	$\theta = 0^\circ$
Reversed (full chain case)	5R/Yellow	5L/Brown	$\theta = 0^\circ$

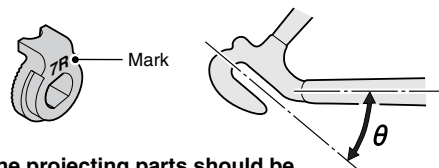

- The projecting parts should be on the fork end side.
- Install the non-turn washers so that the projecting parts is securely in the fork end grooves on either side of the hub axle.

- Install the brake arm of the Inter-M brake to the chainstay with the brake arm clip, provisionally tighten the clip screw and clip nut, and then tighten the brake unit fixing nut.

**Note:**

If the brake arm is in the incorrect position as shown in the illustration so that it cannot be provisionally installed to the chainstay, loosen the brake unit fixing nut and turn the brake arm. Then, after provisionally securing the brake arm to the chainstay, tighten the brake unit fixing nut.

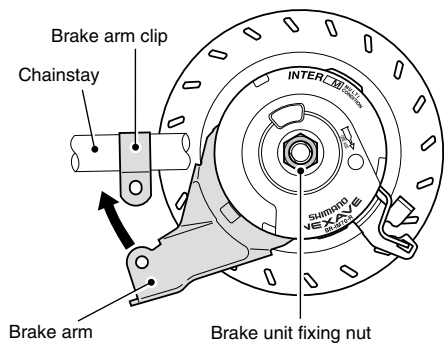

**Tightening torque:**  
20 – 25 Nm {174 – 217 in. lbs.}

- Take up the slack in the chain and secure the wheel to the frame with the cap nuts.

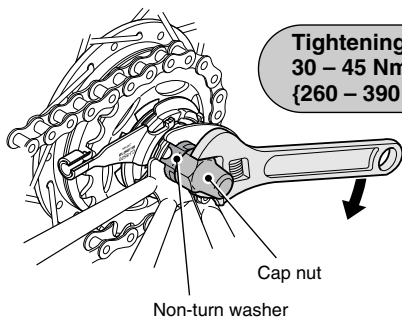

**Tightening torque:**  
30 – 45 Nm  
{260 – 390 in. lbs.}

**Note:**

When installing a part such as a mudguard stay to the hub axle, install in the order shown in the illustration below.

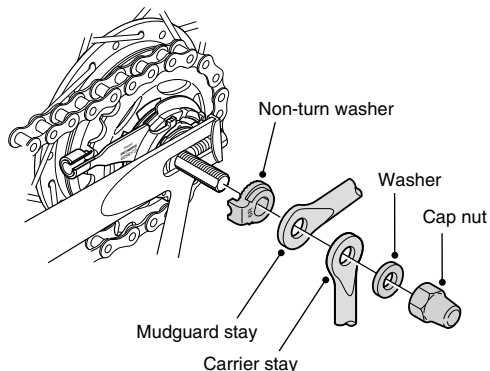

- Fix the brake arm of the Inter-M brake securely to the chainstay with the brake arm clip.

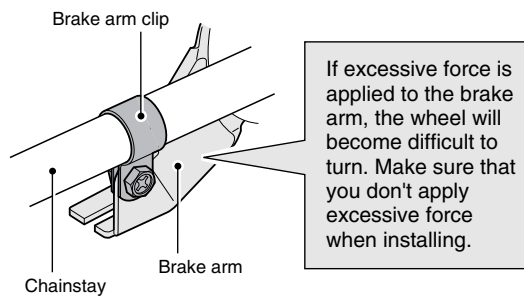

If excessive force is applied to the brake arm, the wheel will become difficult to turn. Make sure that you don't apply excessive force when installing.

**Note:**

- When installing the brake arm clip, securely tighten the clip screw while holding the clip nut with a 10 mm spanner.

**Tightening torque:**  
2 – 3 Nm {17 – 26 in. lbs.}

- After installing the brake arm clip, check that the clip screw protrudes about 2 – 3 mm from the surface of the clip nut.

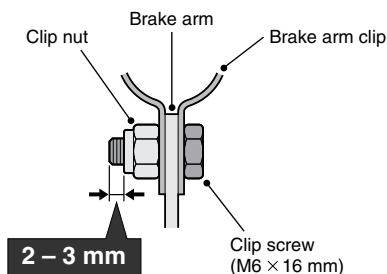

These service instructions explain how to use and maintain the Shimano bicycle parts which have been used on your new bicycle. For any questions regarding your bicycle or other matters which are not related to Shimano parts, please contact the place of purchase or the bicycle manufacturer.

These service instructions are printed on recycled paper.

Please note: Specifications are subject to change for improvement without notice. (English)

**SHIMANO®**

**SHIMANO AMERICAN CORPORATION**  
One Holland Irvine CA 92618 U.S.A. Phone 949-951-5003

**SHIMANO EUROPA**  
Industrieweg 24 NL-8071 CT Nunspeet, Holland Phone 31-341-272222

**SHIMANO INC.**  
3-77 Oimatsucho, Sakai, Osaka, Japan Phone 072-223-3243

© Apr. 2003 by Shimano Inc. PIT. SZK. Printed in Japan

