

SL-R440-8

Shifting lever

Before use, read these instructions carefully, and follow them for correct use.

⚠ WARNING

- Obtain, read and carefully service instructions when installing parts. A loose, worn, or damaged parts may cause injury to the rider. We strongly recommend that only genuine Shimano replacement parts be used.

Note

- For smooth operation, use the specified outer casing and bottom bracket cable guide.
- Grease the inner cable and the inside of the outer casing before use to ensure that they slide properly.
- Because the high cable resistance of a frame with internal cable routing would impair the SIS function, this type of frame should not be used.
- Operation of the levers related to gear shifting should be made only when the front chainwheel is turning.
- Use an outer casing which still has some length to spare even when the handlebars are turned all the way to both sides. Furthermore, check that the shifting lever does not touch the bicycle frame when the handlebars are turned all the way.
- Do not disassemble the indicator and shifting lever unit, as this may damage them or cause mis-operation.
- For maximum performance we highly recommend Shimano lubricants and maintenance products.
- For any questions regarding methods of installation, adjustment, maintenance or operation, please contact a professional bicycle dealer.

In order to realize the best performance, we recommend that the following combination be used.

Shifting lever	Front	SL-R440
	Rear	SL-R440-8
Outer casing		SP40
Gears		16
Front derailleur		FD-R440A
Front chainwheel		FC-3300
Bottom bracket		BB-UN40
Rear derailleur		RD-3300
Freehub		FH-3300
Cassette sprocket		CH-HG50-8
Chain		CN-HG50
Bottom bracket cable guide		SM-SP17

Shifting lever	Front	SL-R440
	Rear	SL-R440-8
Outer casing		SP40
Gears		24
Front derailleur		FD-R443A
Front chainwheel		FC-3303
Bottom bracket		BB-UN40
Rear derailleur		RD-3300
Freehub		FH-3300
Cassette sprocket		CS-HG50-8
Chain		CN-HG50
Bottom bracket cable guide		SM-SP17

Gear shifting operation

Both lever (A) and lever (B) always return to the initial position when they are released after shifting. When operating one of the levers, always be sure to turn the crank arm at the same time.

< Front >

To shift from a small chainring to a larger chainring

When lever (A) is pressed once, there is a shift of one step from a small chainring to a larger chainring.

Example:

from intermediate chainring to largest chainring.

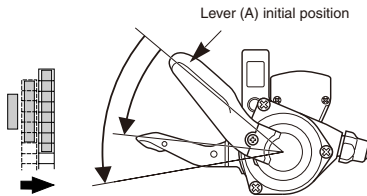

To shift from a large chainring to a smaller chainring

When lever (B) is pressed once, there is a shift of one step from a large chainring to a smaller chainring.

Example:

from largest chainring to intermediate chainring.

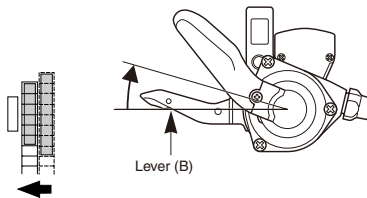

When lever (B) is operated, there is one click where trimming (the noise prevention mechanism) engages, and a second stronger click when the gear shift stroke is completed. After trimming, the next push will complete the gear shift stroke to the smaller front chainring.

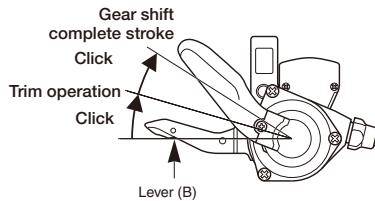

Trimming (noise prevention operation)

If the chain is on the large front chainwheel and the larger rear sprocket, the chain will rub in the front derailleur plate, producing a characteristic noise. When this happens, press lever (B) lightly (to the point where it clicks); this causes the front derailleur to move slightly towards the smaller chainwheel, thereby eliminating the noise.

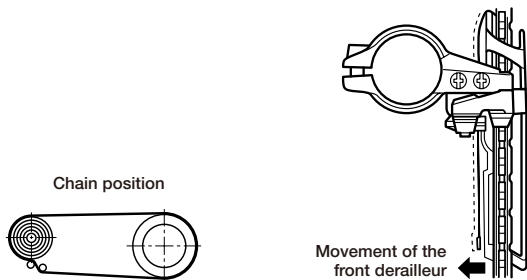

< Rear >

To shift from a small sprocket to a larger sprocket

To shift one step only, press lever (A) to the ① position. To shift two steps at one time, press to the ② position. A maximum three-step shift can be made in this manner.

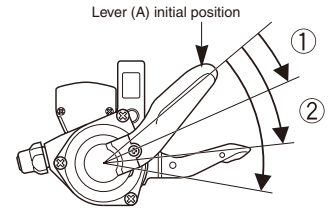

① : Shifts one sprocket
E.x. : from 3rd to 4th

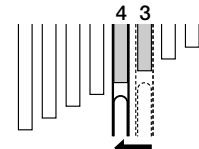

② : Quick-shifts two sprockets
E.x. : from 3rd to 5th

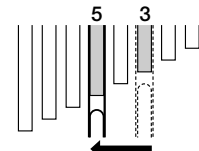

③ : Quick-shifts three sprockets
E.x. : from 3rd to 6th

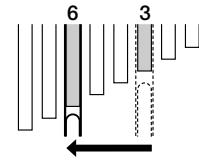

To shift from a large sprocket to a smaller sprocket

Press lever (B) once to shift one step from a larger to a smaller sprocket.

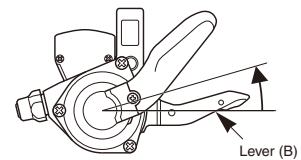

E.x. : from 4th to 3rd

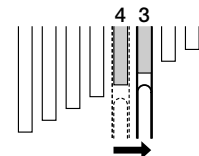

Mounting the shifting lever

Use a handlebar grip with a maximum outer diameter of 32 mm.

Install the brake lever in a position where it will not obstruct brake operation. Do not use in a combination which causes brake operation to be obstructed.

Tightening torque :
5 Nm {44 in. lbs.}

< Front >

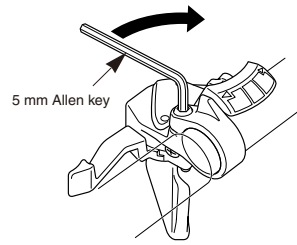

< Rear >

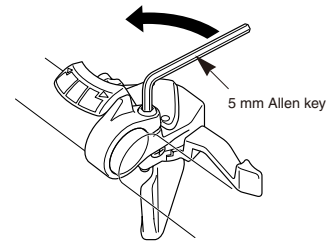

Installing the shifting cable

Inserting the inner cable

Insert the inner cable into the outer casing from the end with the marking on it. Apply grease from the end with the marking in order to maintain cable operating efficiency.

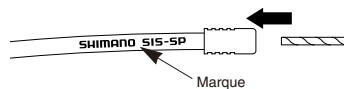

Cutting the outer casing

When cutting the outer casing, cut the opposite end to the end with the marking. After cutting the outer casing, make the end round so that the inside of the hole has a uniform diameter.



Attach the same outer end cap to the cut end of the outer casing.

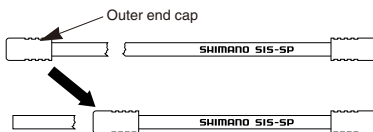

Installing the inner cable < Front >

Operate lever (B) 2 times or more, and check on the indicator that the lever is at the lowest position. Then remove the inner hole cover and connect the inner cable.

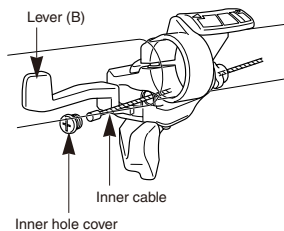

Tightening torque:
5 - 7 Nm {44 - 60 in. lbs.}

Installing the inner cable < Rear >

Operate lever (B) 7 times or more, and check on the indicator that the lever is at the highest position. Then remove the inner hole cover and connect the inner cable.

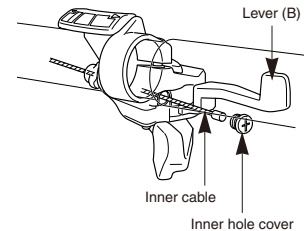

Tightening torque :
5 - 7 Nm {44 - 60 in. lbs.}

Install the inner hole cover by turning it as shown in the illustration until it stops. Do not turn it any further than this, otherwise it may damage the screw thread.

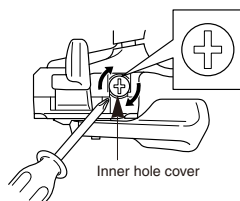

Tightening torque:
0.3 - 0.4 Nm {3 - 4 in. lbs.}

Install the inner hole cover by turning it as shown in the illustration until it stops. Do not turn it any further than this, otherwise it may damage the screw thread.

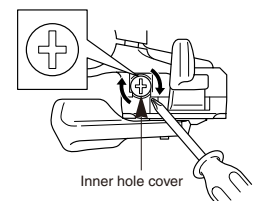

Tightening torque :
0.3 - 0.5 Nm {3 - 4 in. lbs.}

Replacement of the shifting lever unit and indicator

< Front >

Removal of the indicator

Disassembly and reassembly should only be carried out when replacing the indicator.

1. Remove the two indicator set screws which are securing the indicator.

Tightening torque : 0.3 - 0.5 Nm {3 - 4 in. lbs.}

2. Remove the indicator unit as shown in the illustration.

3. Operate lever (B) 2 times or more to set the lever to the lowest position.

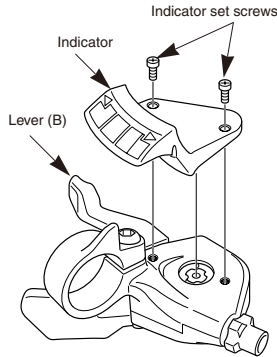

4. After checking that the indicator needle is at the right edge, install the indicator as shown in the illustration.

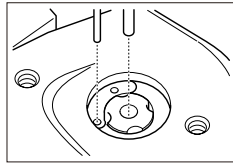

5. Check the operation of the indicator. If it does not operate correctly, re-install the indicator by while taking particular note of steps 3. and 4.

Replacement of the shifting lever unit

Disassembly and reassembly should only be carried out when replacing the shifting lever unit.

1. Loosen the cable fixing bolt (nut) of the front derailleur, and then pull the inner cable out of the shifting lever unit in the same way as when installing the inner cable.

2. Carry out steps 1 - 2 for replacement of the indicator.

3. Remove the three shifting lever mounting screws, and then remove the shifting lever unit as shown in the illustration.

Tightening torque :
0.5 - 0.8 Nm {4 - 7 in. lbs.}

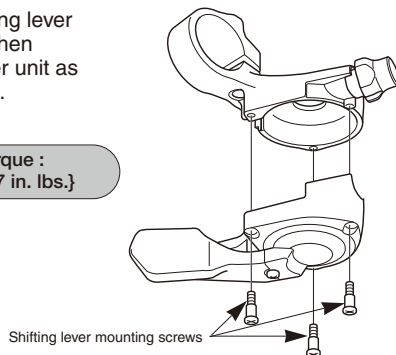

4. To assemble, align the shifting lever unit and the brake lever bracket and then secure the shifting lever mounting screws.

5. Carry out steps 3 - 4 for replacement of the indicator.

< Rear >

Removal of the indicator

Disassembly and reassembly should only be carried out when replacing the indicator.

1. Remove the two indicator set screws which are securing the indicator.

Tightening torque : 0.3 - 0.5 Nm {3 - 4 in. lbs.}

2. Remove the indicator unit as shown in the illustration.

3. Operate lever (B) at least 7 times to set the lever to the highest position.

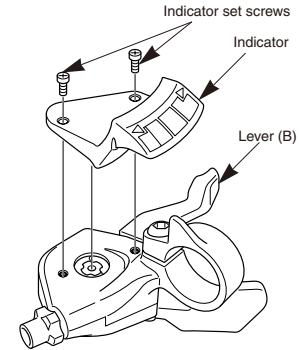

4. After checking that the indicator needle is at the right edge, install the indicator as shown in the illustration.

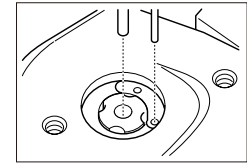

5. Check the operation of the indicator. If it does not operate correctly, re-install the indicator by while taking particular note of steps 3. and 4.

Replacement of the shifting lever unit

Disassembly and reassembly should only be carried out when replacing the shifting lever unit.

1. Loosen the cable fixing bolt (nut) of the rear derailleur, and then pull the inner cable out of the shifting lever unit in the same way as when installing the inner cable.

2. Carry out steps 1 - 2 for replacement of the indicator.

3. Remove the three shifting lever mounting screws, and then remove the shifting lever unit as shown in the illustration.

Tightening torque :
0.5 - 0.8 Nm {4 - 7 in. lbs.}

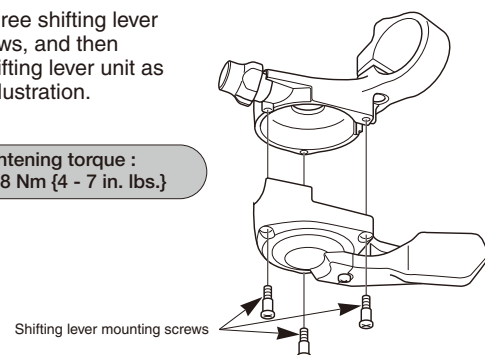

4. To assemble, align the shifting lever unit and the brake lever bracket and then secure the shifting lever mounting screws.

5. Carry out steps 3 - 4 for replacement of the indicator.

