



General Safety Information

⚠ WARNING

– To avoid serious injuries:

- It is important to completely understand the operation of your bicycle's brake system. Improper use of your bicycle's brake system may result in a loss of control or an accident, which could lead to severe injury. Because each bicycle may handle differently, be sure to learn the proper braking technique (including brake lever pressure and bicycle control characteristics) and operation of your bicycle. This can be done by consulting your professional bicycle dealer and the bicycle's owners manual, and by practicing your riding and braking technique.
- The ST-EF29 (4-finger)/SB-C055 (4-finger)/ST-C055A/ST-C050 brake levers are equipped with a mode switching mechanism. Be sure to use the BR-C050-IM-R with the mechanism in the C.R mode position.

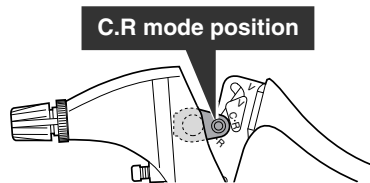

The C indicates the mode position for compatibility with cantilever brakes.
The R indicates the mode position for compatibility with Roller Brakes.

- When securing the brake arm to the frame, be sure to securely tighten the clip screw and clip nut to the specified tightening torque. Use lock nuts with nylon inserts (self-locking nuts) for the clip nut. It is recommended that standard Shimano parts be used for the clip screw, clip nut and brake arm clip. If the clip nut comes off the brake arm, or if the clip screw or brake arm clip becomes damaged, the brake arm may rotate on the chainstay and cause the handlebars to jerk suddenly, or the bicycle wheel may lock and the bicycle may fall over, causing serious injury.
- Obtain and read the service instructions carefully prior to installing the parts. Loose, worn, or damaged parts may cause serious injury to the rider. We strongly recommend only using genuine Shimano replacement parts.

⚠ CAUTION

– To avoid serious injuries:

1. When using the Shimano Inter-M brake system, avoid continuous application of the brakes when riding down long slopes, as this will cause the internal brake parts to become very hot, and this may weaken braking performance. It may also cause a reduction in the amount of brake grease inside the brake, and this can lead to problems such as abnormally sudden braking. The design of the Shimano Inter-M brake system has been carried out based on standards such as ISO 4210 and DIN 79100-2. These standards specify the performance for an overall weight of 100 kg. If the overall weight exceeds 100 kg, the braking force provided by the system may be insufficient for correct braking, and durability of the system may also be reduced.
2. In order to get the best performance from the Shimano Inter-M brake, be sure to use Shimano brakes cables and brake levers as a set.

(The amount of movement of the inner cable must be 14.5 mm or more when the brake lever is depressed. If it is less than 14.5 mm, braking performance will suffer, and the brakes may fail to work.)
3. If the hub nuts are cap nuts, use a frame with fork ends that are at least 7 mm thick.
4. Check that the brake unit is firmly secured to the hub body with the brake unit fixing nut.

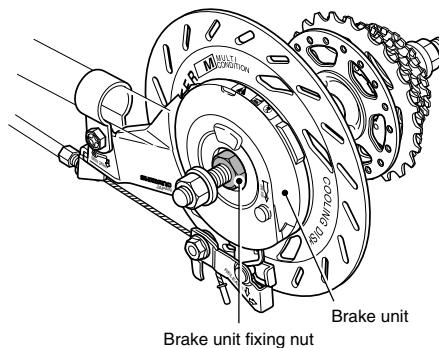

Tightening torque:
20 – 25 Nm
{174 – 217 in. lbs.}

5. Check that the wheel is fixed securely to the frame with the hub nuts.

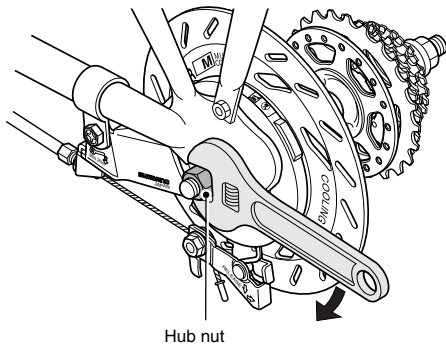

Hub nut

Tightening torque:
30 – 45 Nm
{260 – 390 in. lbs.}

6. Check that the brake arm is securely fastened to the chainstay by the brake arm clip. If it is not installed correctly, braking performance will suffer.

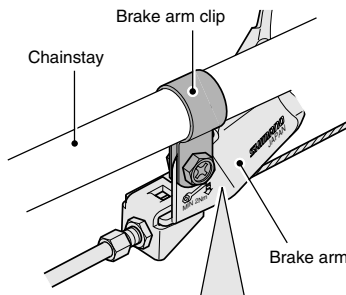

If excessive force is applied to the brake arm, the wheel will become difficult to turn. Make sure that you don't apply excessive force when installing.

When installing the clip screw, securely hold the clip nut with a 10 mm spanner while tightening the clip screw. After tightening, check that the clip screw protrudes about 2 – 3 mm from the surface of the clip nut.

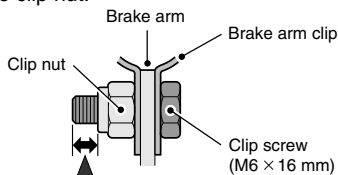

2 – 3 mm

Tightening torque:
2 – 3 Nm {17 – 26 in. lbs.}

7. If any of the following occur while using the brakes, stop riding immediately and ask the place of purchase to carry out inspection and repairs.

- 1) If abnormal noise is heard when the brakes are applied
- 2) If braking force is abnormally strong
- 3) If braking force is abnormally weak

In the case of 1) and 2), the cause might be not enough brake grease, so ask the place of purchase to grease the mechanism with special Roller Brake grease.

8. If the brakes are used frequently, the brake drum may become hot. Do not touch the brake drum for at least 30 minutes after you finish riding the bicycle.

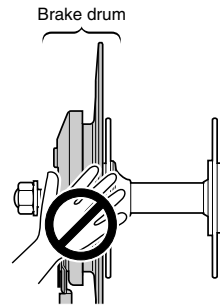

9. If the brake cable becomes rusted, braking performance will suffer. If this happens, replace the brake cable with a genuine Shimano brake cable and re-check the braking performance.

10. The BR-C050-IM-R brake unit should never be disassembled. If it is disassembled, it will no longer work properly.

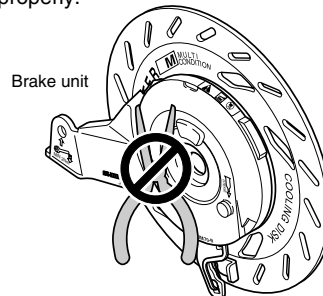

NOTE:

- The Inter-M brake is different from conventional brakes in that the inside of the brake drum is filled with grease. This may cause the turning of the wheel to be slightly heavier than usual, particularly in cold weather.

- For maximum performance we highly recommend Shimano lubricants and maintenance products.

For any questions regarding methods of handling or

BR-C050-IM-R

Inter-M Brake

Technical Service Instructions

In order to realize the best performance from the Inter-M brake, we recommend that the following combinations be used.

Brake	BR-C050-IM-R
Hub	RH-IM10
Lever	ST-EF29 (4-finger) SB-C055 (4-finger) ST-C055A ST-C050
Brake cable	

Disconnecting the brake cable from the brake unit

1. Push the cam transmission plate until it stops. Then, slide the link unit along the guide groove in the cam transmission plate to remove the link unit. If the link unit is difficult to remove, turn the cable adjusting bolt clockwise to release the cable tension first.

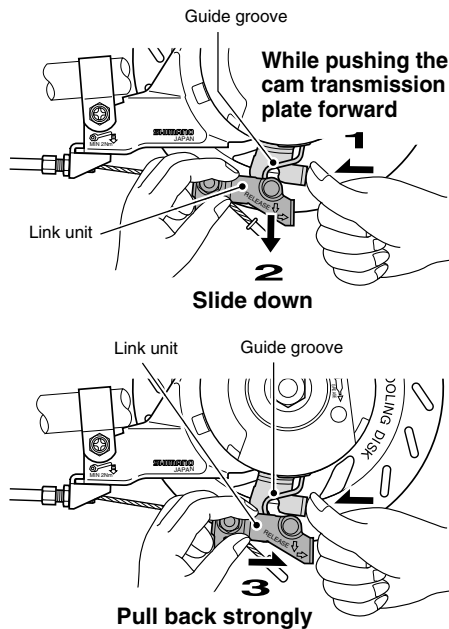

2. Slide the outer casing holder along the guide slot in the brake arm to remove it from the slot.

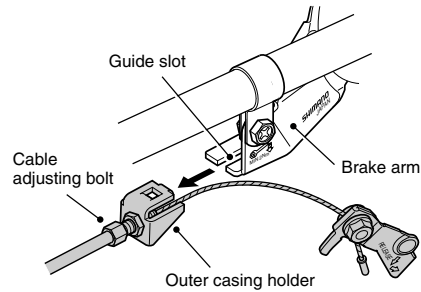

To install the brake cable again, carry out the above procedure in reverse.

Note:

- When installing the link unit to the cam transmission plate, push the link unit in until it clicks, and check that it is securely in the position shown in the illustration.

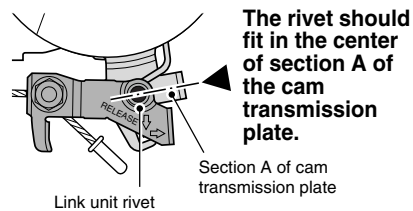

- Depress the brake lever to check the braking performance. If the braking performance is poor, adjust the brake cable once more while referring to "Adjusting the brake cable".

Installing the brake cable

1. Slide the outer casing holder along the guide slot in the brake arm to set it into the slot.

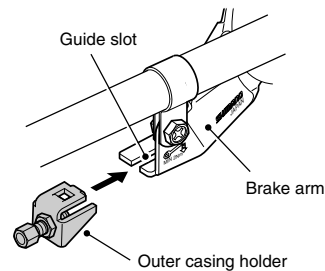

2. Hold the cam transmission plate with your hand, and slide the link unit along the guide groove in the cam transmission plate to install the link unit.

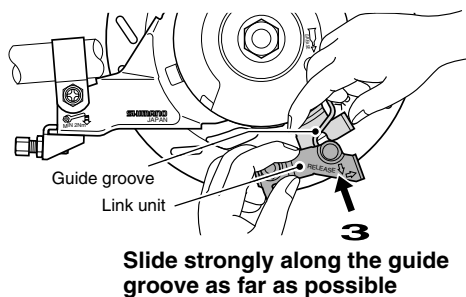
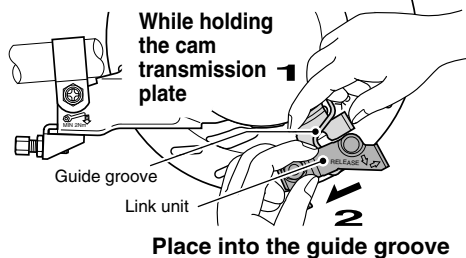

Note:

When installing the link unit to the cam transmission plate, push the link unit in until it clicks, and check that it is securely in the position shown in the illustration.

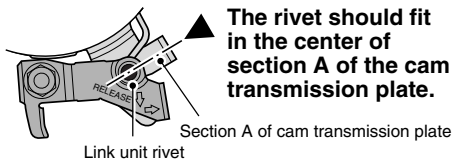

3. Place the cable adjusting bolt so that it is 15 – 17 mm from the end of the outer casing holder, and then pass the inner cable through the cable adjusting bolt and then through the hole in the inner cable fixing bolt.

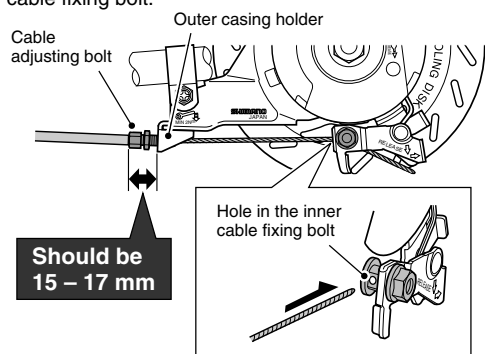

4. Check that both ends of the outer casing are securely inserted into the cable adjusting bolts of both the brake lever and brake arm.

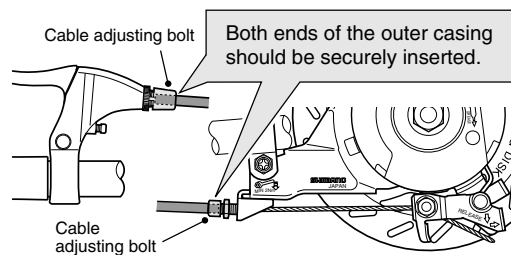

5. Push the cam transmission plate back until it stops. Then, while pulling the inner cable to apply the full amount of tension to the cable, tighten the inner cable fixing nut.

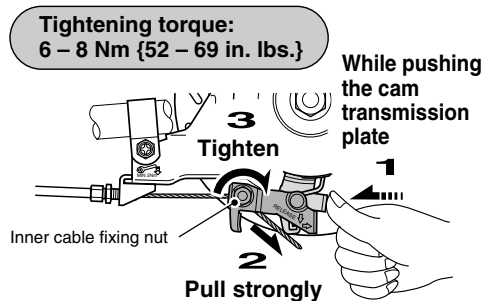

Note:

After tightening the inner cable fixing nut, attach the inner end cap to the end of the inner cable. Then set the inner end cap so that it does not touch the link and the spokes.

Adjusting the brake cable

1. After checking that the wheel does not easily turn while the brake cable is being pulled, depress the brake lever about 10 times as far as the grip in order to run in the brake cable.

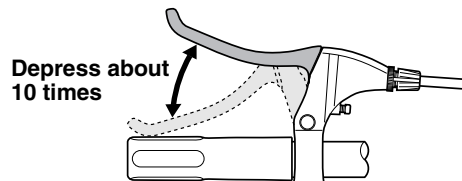

Note:

If the brake cable is not run in, it will need to be adjusted again after only a short period of use.

2. Turn the cable adjusting bolt of the brake unit or brake lever so that there is about 15 mm of play in the brake lever.

(The amount of brake lever play is the distance from the position where the brake lever is not operated to the position where a force is felt suddenly when the brake lever is pulled.)

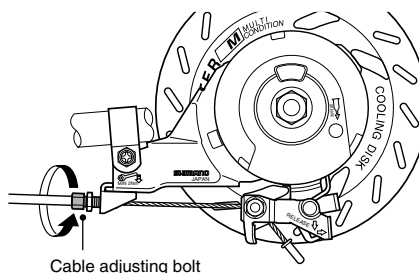
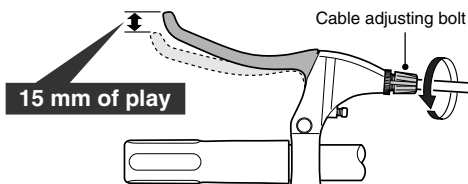

3. After depressing the brake lever to check the braking performance, secure the cable adjusting bolt with the cable adjusting nut.

Tightening torque:
1 – 2 Nm
{9 – 17 in. lbs.}

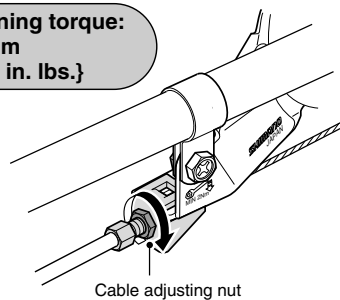

Cable adjusting nut

These service instructions explain how to use and maintain the Shimano bicycle parts which have been used on your new bicycle. For any questions regarding your bicycle or other matters which are not related to Shimano parts, please contact the place of purchase or the bicycle manufacturer.

These service instructions are printed on recycled paper.

Please note: Specifications are subject to change for improvement without notice. (English)

SHIMANO®

SHIMANO AMERICAN CORPORATION
One Holland Irvine CA 92618 U.S.A. Phone 949-951-5003

SHIMANO EUROPA
Industrieweg 24 NL-8071 CT Nunspeet, Holland Phone 31-341-272222

SHIMANO INC.
3-77 Oimatsucho, Sakai, Osaka, Japan Phone 072-223-3243

© Mar. 2003 by Shimano Inc. PIT. SZK. Printed in Japan

