



Front Drive System

Before use, read these instructions carefully, and follow them for correct use.

CAUTION

- Be sure to use only a Shimano HG chain in combination with the FC-T300/FC-T301 front chainwheels.

Note

- Apply grease to the bottom bracket before installing it.
- For smooth operation, always be sure to use the specified outer casing and the bottom bracket cable guide.
- This front derailleur is for triple front chainwheel use only. It cannot be used with the double front chainwheel, as the shifting points do not match.
- When installing the top route type, choose a frame that has three outer casing holders as shown in the illustration at right.
- Use an outer casing which still has some length to spare even when the handlebars are turned all the way to both sides. Furthermore, check that the shifting lever does not touch the bicycle frame when the handlebars are turned all the way.
- Grease the inner cable and the inside of the outer casing before use to ensure that they slide properly.
- For any questions regarding methods of installation, adjustment, maintenance or operation, please contact a professional bicycle dealer.

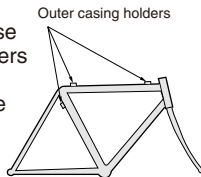

In order to realize the best performance, we recommend that the following combination be used.

Series	NEXAVE
Rapidfire Plus	ST-T300
Outer casing	SP40 sealed outer casing
Front derailleur	FD-T300/FD-T301 FD-T300-E
Front chainwheel	FC-T300 / FC-T301
Bottom bracket	BB-CT92 / BB-CS15
Chain	CN-HG50
Bottom bracket cable guide	SM-SP18 / SM-BT18

Specifications

Front Derailleur

Model number	FD-T300	FD-T300-E	FD-T301
Normal type	○	○	○
Top route type	○	○	○
Front chainwheel tooth difference	18T	18T	20T
Min. difference between top and intermediate	8T	8T	10T
Front derailleur installation band diameter	S, M	S, M	S, M
Chainstay angle (α)	63° - 66°, 66° - 69°	63° - 66°, 66° - 69°	63° - 66°, 66° - 69°
Applicable chain line	47.5mm, 50.0mm	47.5mm, 50.0mm	47.5mm, 50.0mm

Installation band diameters:
S (28.6 mm), M (31.8 mm)

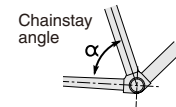

Front chainwheel	FC-T300 (42T-34T-24T) 170mm					
Front derailleur	FD-T300			FD-T300-E		
Combination	With chain protector	Without chain protector	With chain protector	Without chain protector		
B.B. Width	68mm	68mm	73mm	68mm	68mm	73mm
	Model number BB-CT92					
B.B.	Spindle length	YL116	ZL121	YL116	ZL121	
	Shell width	68mm	73mm	68mm	73mm	
Chain line	47.5mm+T1	47.5mm	50mm	47.5mm+T1	47.5mm	50mm
Spacer (2.5mm)	○	○	○			

Front chainwheel	FC-T301 (48T-38T-28T) 170mm					
Front derailleur	FD-T301					
Combination	With chain protector	Without chain protector	When using SM-FD30	When using SM-FD30 and chain protector		
B.B. Width	68mm	68mm	73mm	68mm	68mm	
	Model number BB-CS15					
B.B.	Spindle length	D-NL122.5	D-EL 127.5	D-NL 122.5	D-NL122.5	
	Shell width	68mm	73mm	73mm	73mm	
Chain line	47.5mm+T1	47.5mm	50mm	47.5mm	47.5mm+T1	

* T1 is the thickness of the chain protector.

Installation of the Front Derailleur, Bottom Bracket and Front Chainwheel

< FD-T300 / FD-T301 >

Install using the TL-UN74-S special tool. First install the main body, then the adapter. After this, use an 8 mm Allen key to install the front chainwheel.

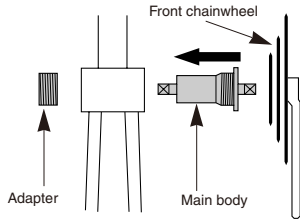

Adapter / bottom bracket tightening torque:
50 - 70 Nm {435 - 608 in. lbs.}
Front chainwheel tightening torque:
35 - 50 Nm {305 - 435 in. lbs.}

Adjust and then install the front derailleur as shown in the illustration. Do not remove the Pro-Set alignment block at this time.

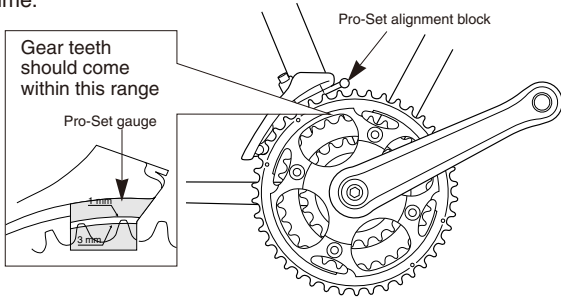

The level section of the chain guide outer plate should be directly above and parallel to the largest chainring. Secure using a 5 mm Allen key.

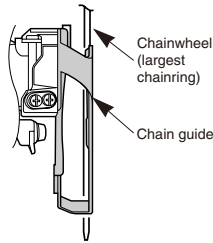

Tightening torque:
5 - 7 Nm {44 - 60 in. lbs.}

< FD-T300-E >

Use the special tools (TL-UN65 and TL-UN74-S) to install the bottom bracket ① and the front derailleur so that they face as shown in the illustration. Install the adapter ②, and then use the cotterless crank extractor (TL-FC10) to install the front chainwheel.

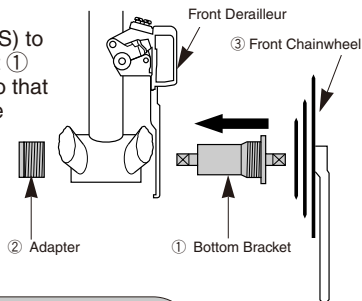

Adapter / bottom bracket tightening torque:
50 - 70 Nm {435 - 608 in. lbs.}
Front chainwheel tightening torque:
35 - 50 Nm {305 - 435 in. lbs.}

Chain length

Add 2 links (with the chain on both the largest sprocket and the largest chainring)

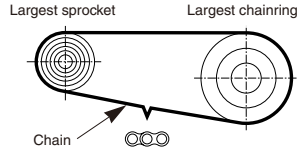

Checking the chain connection

For chains, insert the chain gauge (TL-CN24) into the inner link which is next to the chain connecting pin to check that the inner link width is correct. Check that the connecting pin protrudes past the outer link by the same amount on both sides, and that the amount of protrusion is 0.2 mm or more.

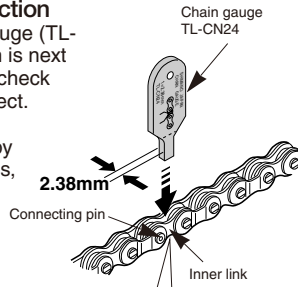

$A, B \geq 0.2\text{mm}$

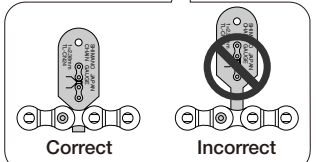
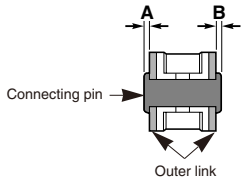

Installation of the brake lever

Use a handlebar grip with a maximum outer diameter of 32 mm.

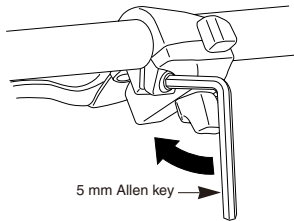

Tightening torque:
6-8 Nm {53-69 in. lbs.}

SIS adjustment

Be sure to follow the sequence described below.

1. Low adjustment

First remove the Pro-Set alignment block.

Next, set so that the clearance between the chain guide inner plate and the chain is 0-0.5 mm.

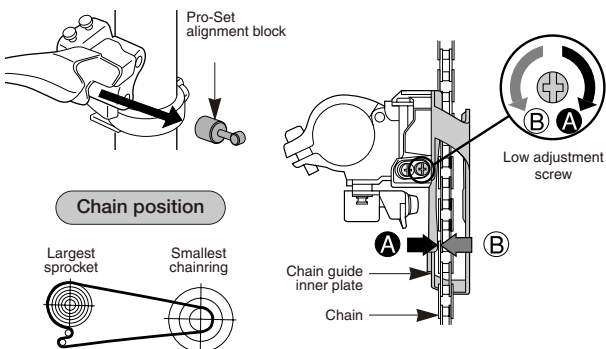

2. Connection and securing of the inner cable

Press button (B) 2 or more times to set the lever to the lowest position, check on the indicator that the highest position is correct, and then install and adjust the inner cable.

Loosen the screw, remove the cover and then pass the inner cable through the cable adjustment bolt as shown in the illustration. Run the cable along the slit in the winding reel and hook it into the hole in the winding reel. The inner end cap should be pressed into the hole in the winding reel as far as it will go.

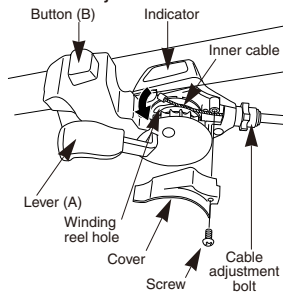

While firmly pulling the inner cable, secure by tightening the fixing bolt with a 5 mm Allen key.

Tightening torque:
5 - 7 Nm
{44 - 60 in. lbs.}

Inserting the inner cable

Insert the inner cable into the outer casing from the end with the marking on it. Apply grease from the end with the marking in order to maintain cable operating efficiency.

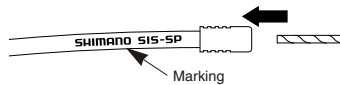

Cutting the outer casing

When cutting the outer casing, cut the opposite end to the end with the marking. After cutting the outer casing, make the end round so that the inside of the hole has a uniform diameter.



Attach the same outer end cap to the cut end of the outer casing.

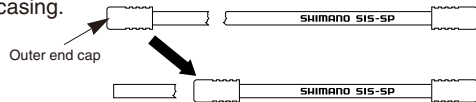

Cut off any unnecessary cable, attach an end cup and hook it onto the pin.

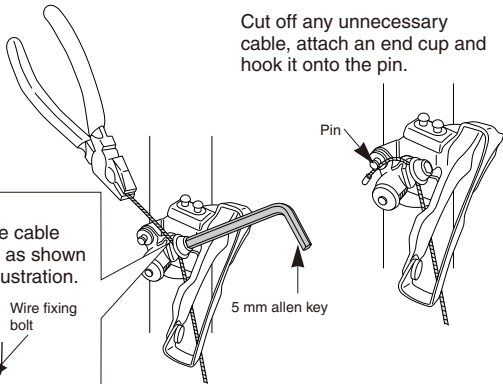

Note:
Pass the cable through as shown in the illustration.

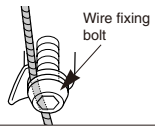

Tightening torque:
5 - 7 Nm {44 - 60 in. lbs.}

After taking up the initial slack in the cable, re-secure to the front derailleur as shown in the illustration.

Normal type

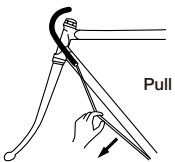

Top route type

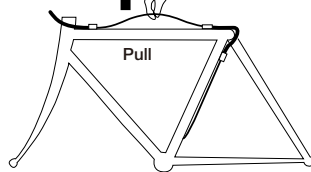

3. Top adjustment

Set so that the clearance between the chain guide outer plate and the chain is 0-0.5 mm.

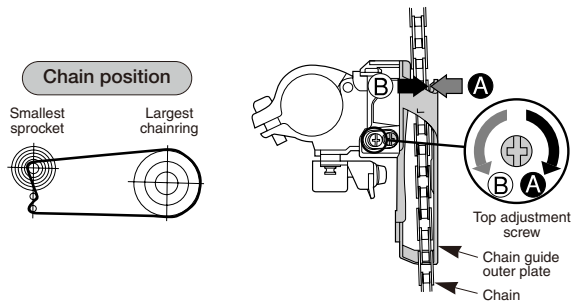

4. Adjustment of the intermediate chainring

When carrying out adjustment, set the chain to the largest sprocket, and at the front, set the chain to the intermediate chainring. Adjust using the outer casing adjustment barrel so that the clearance between the chain guide inner plate and the chain is 0-0.5 mm.

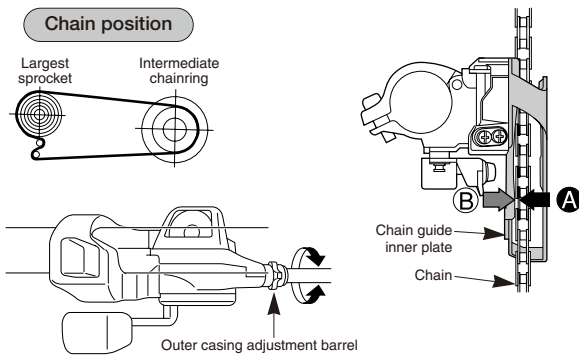

5. Troubleshooting chart

After completion of steps 1 - 4, move the shifting lever to check the shifting. (This also applies if shifting becomes difficult during use.)

If the chain falls to the crank side.	Tighten the top adjustment screw clockwise (about 1/4 turn).
If shifting is difficult from the intermediate chainring to the largest chainring.	Loosen the top adjustment screw counterclockwise (about 1/8 turn).
If shifting is difficult from the intermediate chainring to the smallest chainring.	Loosen the low adjustment screw counterclockwise (about 1/4 turn).
If there is interference between the chain and the front derailleur inner plate at the largest chainring.	Tighten the top adjustment screw clockwise (about 1/8 turn).
If there is interference between the chain and the front derailleur outer plate at the largest chainring.	Loosen the top adjustment screw counterclockwise (about 1/8 turn).
If the intermediate chainring is skipped when shifting from the largest chainring.	Loosen the outer casing adjustment barrel counterclockwise (1 or 2 turns).
If there is interference between the chain and front derailleur inner plate when the rear sprocket is shifted to the largest sprocket when the chainwheel is at the intermediate chainring position.	Tighten the outer casing adjustment barrel clockwise (1 or 2 turns).
If the chain falls to the bottom bracket side.	Tighten the low adjustment screw clockwise (about 1/2 turn).

Replacing the indicator

1. Press button (B) to set the lever to the lowest position.
2. Insert the pin of the indicator gear into the hole of the winding reel.
3. Move the indicator needle to the [1] position.
4. In the condition in step 3., place the indicator on top of the brake lever bracket. Be careful not to let the indicator needle move at this time.
5. Secure the indicator with the two indicator set screws.

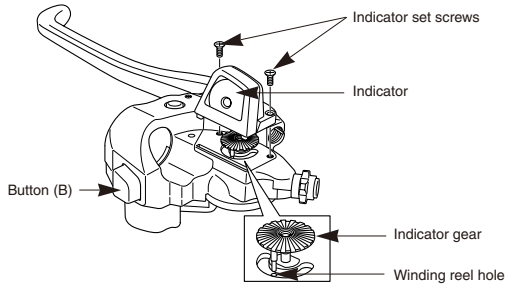

Gear shifting operation

Both lever (A) and button (B) return to the initial lever or button position when they are released after shifting. When operating lever (A) or button (B), always be sure to turn the crank arm at the same time.

To shift from a small chainring to a larger chainring

When lever (A) is pressed once, there is a shift of one step from a small chainring to a larger chainring.

Example:
from intermediate chainring to largest chainring.

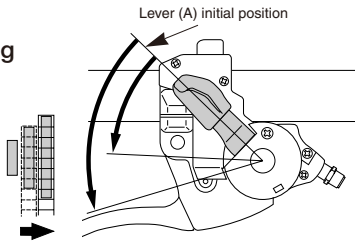

To shift from a large chainring to a smaller chainring

When button (B) is pressed once, there is a shift of one step from a large chainring to a smaller chainring.

Example:
from largest chainring to intermediate chainring.

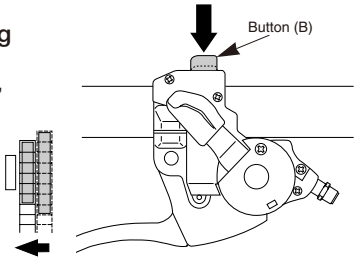

This service instruction explains how to use and maintain the Shimano bicycle parts which have been used on your new bicycle. For any questions regarding your bicycle or other matters which are not related to Shimano parts, please contact the place of purchase or the bicycle manufacturer.

SHIMANO®

SHIMANO AMERICAN CORPORATION
One Holland Irvine CA 92618 U.S.A. Phone 949-951-5003

SHIMANO EUROPA
Industrieweg 24 NL-8071 CT Nunspeet Holland Phone 31-341-272222

SHIMANO INC.
77 Oimatsu-cho 3-cho Sakai Osaka 590-8577 Japan Phone 0722-23-3243

Please note: specifications are subject to change for improvement without notice. (English)
© Apr. 1998 by Shimano Inc. XBC SZK Printed in Malaysia

