



Front Drive System

Before use, read these instructions carefully, and follow them for correct use.

⚠ WARNING

- Use neutral detergent to clean the chain. Do not use alkali-based or acid based detergent such as rust cleaners as it may result in damage and/or failure of the chain.
- Use the reinforced connecting pin only for connecting the narrow type of chain.
- There are two different types of reinforced connecting pin available. Be sure to check the table below before selecting which pin to use. If connecting pins other than reinforced connecting pins are used, or if a reinforced connecting pin or tool which is not suitable for the type of chain is used, sufficient connection force may not be obtained, which could cause the chain to break or fall off.

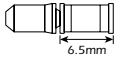
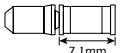
Chain	Reinforced connecting pin	Chain tool
9-speed super narrow chain such as CN-7701 / CN-HG93	 Silver 6.5mm	TL-CN31/TL-CN22
8-/7-/6-speed narrow chain such as CN-HG50 / CN-IG51	 Black 7.1mm	TL-CN31/TL-CN22 and TL-CN30/TL-CN21

- If it is necessary to adjust the length of the chain due to a change in the number of sprocket teeth, make the cut at some other place than the place where the chain has been joined using a reinforced connecting pin or an end pin. The chain will be damaged if it is cut at a place where it has been joined with a reinforced connecting pin or an end pin.

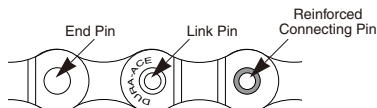

- Obtain, read and carefully service instructions when installing parts. A loose, worn, or damaged parts may cause injury to the rider. We strongly recommend that only genuine Shimano replacement parts be used.

Note

- Apply grease to the bottom bracket before installing it.
- For smooth operation, use the specified outer casing and bottom bracket cable guide.
- This front derailleur is for triple front chainwheel use only. It cannot be used with the double front chainwheel, as the shifting points do not match.
- When installing the top route type, choose a frame that has three outer casing holders as shown in the illustration at right.
- Use an outer casing which still has some length to spare even when the handlebars are turned all the way to both sides. Furthermore, check that the shifting lever does not touch the bicycle frame when the handlebars are turned all the way.
- Grease the inner cable and the inside of the outer casing before use to ensure that they slide properly.
- For maximum performance we highly recommend Shimano lubricants and maintenance products.
- For any questions regarding methods of installation, adjustment, maintenance or operation, please contact a professional bicycle dealer.

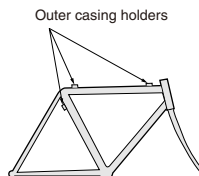

In order to realize the best performance, we recommend that the following combination be used.

Series	C050		
CI-DECK	ID-C050		
Gears	Right	—	
	Left	SIS 3-gears	Friction
REVOSHIFT	SB-C055-L	SB-C055-LN	
Outer casing	SIS40		
Front derailleur	FD-C050 / FD-C051		
Front chainwheel	FC-C050 / FC-C051		
Bottom bracket	BB-TY30		
Chain	CN-UG50		
Bottom bracket cable guide	SM-SP18 / SM-BT18, SM-SP17 / SM-BT17		

Specifications

Front Deraillieur

Model number	FD-C050	FD-C051
Applicable bottom bracket	BB-TY30	
Applicable front chainwheel	FC-C050	FC-C051
Applicable to both normal type and top route type	○	
Top gear tooth	42T	48T
Front chainwheel tooth difference	18T	20T
Min. difference between top and intermediate	8T	10T
Front deraillieur installation band diameter	S, M, L	
Chainstay angle (α)	66°- 69°	
Applicable chain line	47.5 mm, 50 mm	

Installation band diameters:
S [28,6 mm], M [31,8 mm], L [34,9 mm]
(Use the adapter for S and M sizes.)

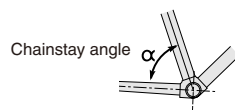

Chainwheel

Model number	FC-C050	FC-C051
Chainwheel tooth combination	42-34-24T	48-38-28T
Crank arm length	160, 170 mm	
Pedal thread dimensions	BC 9/16" x 20 T.P.I.	

Bottom Bracket

Model number	BB-TY30
Stamped marking	D-NL
Spindle length	122.5 mm
Chain line	47.5 mm
Applicable front chainwheel	FC-C050 / FC-C051
Thread dimensions	BC 1.37 X 24 T.P.I. (68, 73 mm) M36 X 24 T.P.I. (70 mm)

Installation of the Front Derailleur, Bottom Bracket and Front Chainwheel

Install using the TL-UN74-S special tool. First install the main body, then the adapter. After this, use an 8 mm Allen key to install the front chainwheel.

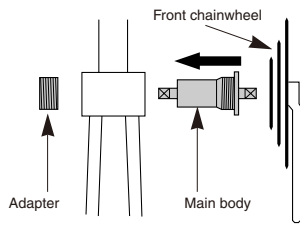

Adapter / bottom bracket tightening torque:
50 - 70 Nm {435 - 608 in. lbs.}
Front chainwheel tightening torque:
35 - 50 Nm {305 - 435 in. lbs.}

Adjust and then install the front derailleur as shown in the illustration. Do not remove the Pro-Set alignment block at this time.

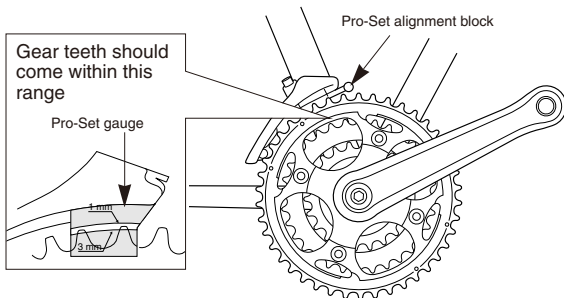

The level section of the chain guide outer plate should be directly above and parallel to the largest chainring. Secure using a 5 mm Allen key.

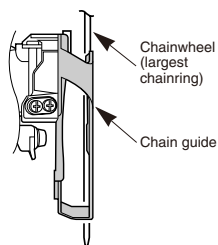

Tightening torque:
5 - 7 Nm {44 - 60 in. lbs.}

Chain length

Add 2 links (with the chain on both the largest sprocket and the largest chainring)

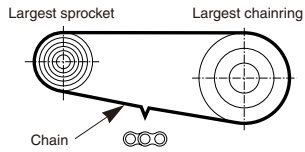

Checking the chain connection

For chains, insert the chain gauge (TL-CN24) into the inner link which is next to the chain connecting pin to check that the inner link width is correct.

Check that the connecting pin protrudes past the outer link by the same amount on both sides, and that the amount of protrusion is 0.2 mm or more.

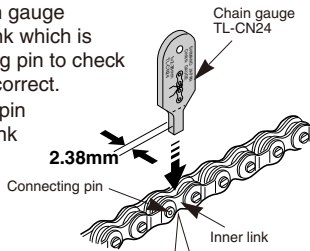

$A, B \geq 0.2\text{mm}$

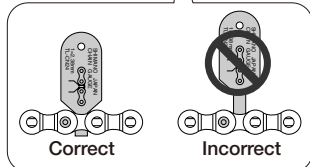
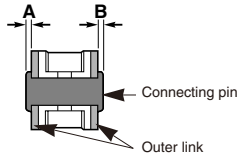

Mounting the shifting lever

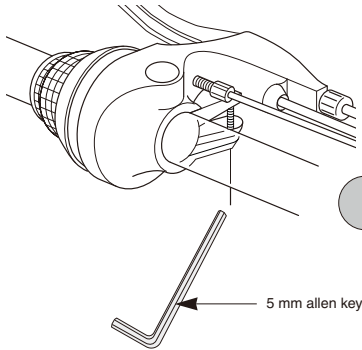

Tightening torque:
6 - 8 Nm {53 - 69 in. lbs.}

Gear shifting operation

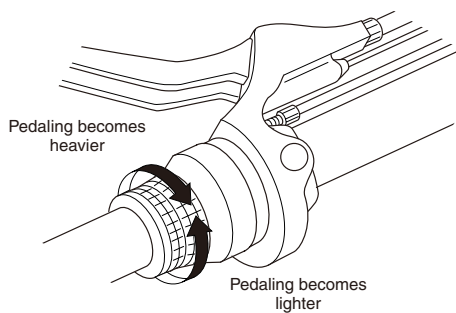

SIS adjustment

Be sure to follow the sequence described below.

1. Low adjustment

First remove the Pro-Set alignment block .

Next, set so that the clearance between the chain guide inner plate and the chain is 0-0.5 mm.

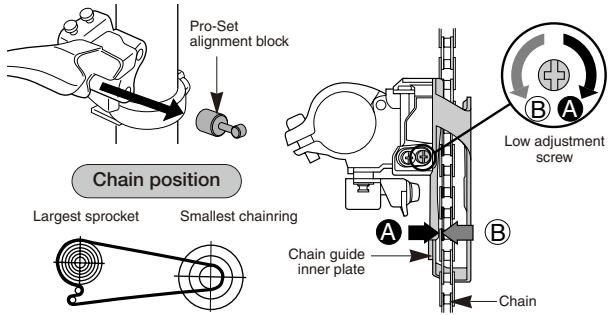

2. Securing the inner cable

Inserting the inner cable

Insert the inner cable into the outer casing from the end with the marking on it. Apply grease from the end with the marking in order to maintain cable operating efficiency.

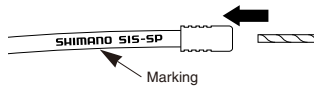

Cutting the outer casing

When cutting the outer casing, cut the opposite end to the end with the marking. After cutting the outer casing, make the end round so that the inside of the hole has a uniform diameter.



Attach the same outer end cap to the cut end of the outer casing.

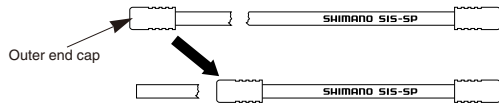

Cut off the excess length of inner cable and then install the inner end cap.

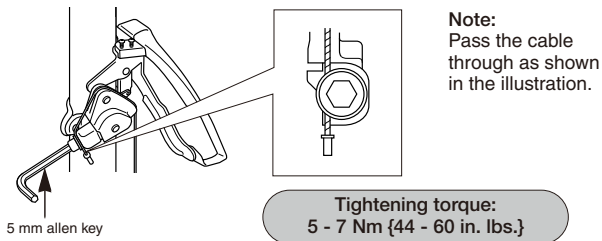

After taking up the initial slack in the cable, re-secure to the front derailleur as shown in the illustration.

Normal type

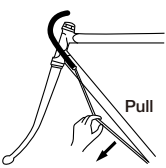

Top route type

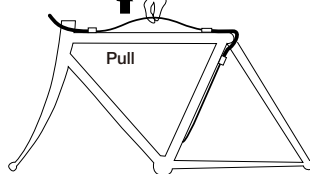

3. Top adjustment

Set so that the clearance between the chain guide outer plate and the chain is 0-0.5 mm.

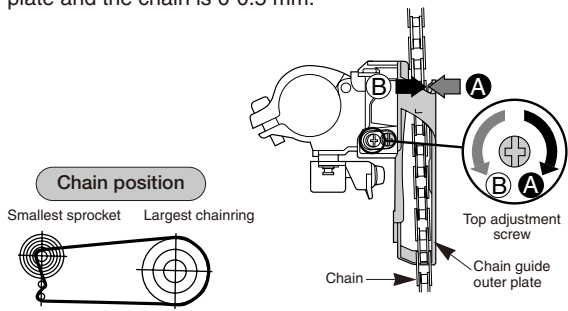

4. Adjustment of the intermediate chainring

When carrying out adjustment, set the chain to the largest sprocket, and at the front, set the chain to the intermediate chainring. Adjust using the outer casing adjustment barrel so that the clearance between the chain guide inner plate and the chain is 0-0.5 mm.

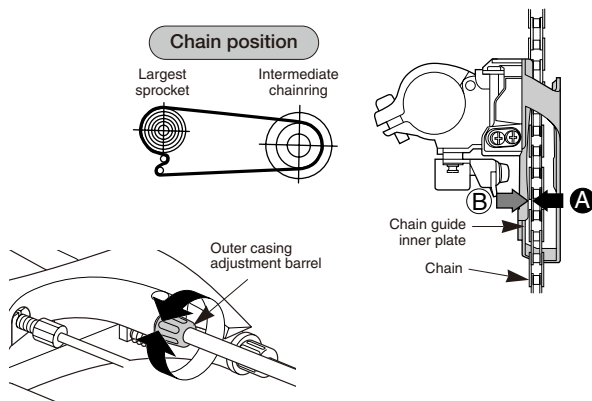

5. Troubleshooting chart

After completion of steps 1 - 4, move the shifting lever to check the shifting. (This also applies if shifting becomes difficult during use.)

If the chain falls to the crank side.	Tighten the top adjustment screw clockwise (about 1/4 turn).
If shifting is difficult from the intermediate chainring to the largest chainring.	Loosen the top adjustment screw counterclockwise (about 1/8 turn).
If shifting is difficult from the intermediate chainring to the smallest chainring.	Loosen the low adjustment screw counterclockwise (about 1/4 turn).
If there is interference between the chain and the front derailleur inner plate at the largest chainring.	Tighten the top adjustment screw clockwise (about 1/8 turn).
If there is interference between the chain and the front derailleur outer plate at the largest chainring.	Loosen the top adjustment screw counterclockwise (about 1/8 turn).
If the intermediate chainring is skipped when shifting from the largest chainring.	Loosen the outer casing adjustment barrel counterclockwise (1 or 2 turns).
If there is interference between the chain and front derailleur inner plate when the rear sprocket is shifted to the largest sprocket when the chainwheel is at the intermediate chainring position.	Tighten the outer casing adjustment barrel clockwise (1 or 2 turns).
If the chain falls to the bottom bracket side.	Tighten the low adjustment screw clockwise (about 1/2 turn).

Installing the CI-Deck

1. Install to a handlebar with a diameter of 25 mm. (Use an adapter if the handlebar diameter is 22 mm.)

2. The CI-Deck can be adjusted within a range of 30 degrees. Loosen the bolt of the clamp band to adjust.

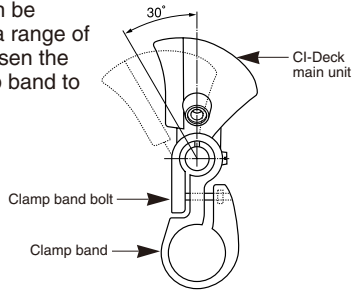

3. The length of the cable which connects the CI-Deck and the Revoshift unit will vary depending on the handlebars being used. If the cable is too long or too short, the indicator display will not be correct.

4. Replacement of the indicator cable

< At the CI-Deck side >

Remove the cover fixing screws and then remove the cover, lens cover and indicator as shown in the illustration.

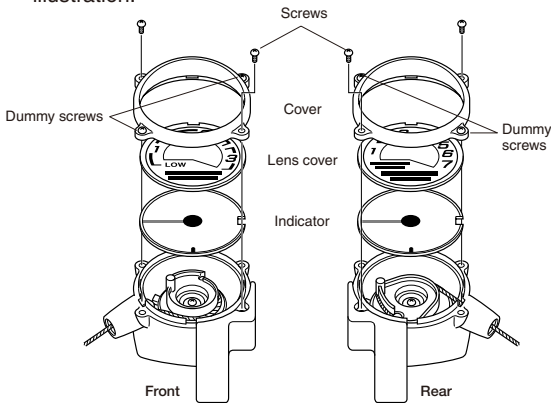

Tightening torque:
0.1 Nm {1 in. lbs.}

Turn the pulley and remove the cable as shown in the illustration. Turn the pulley clockwise, and then insert the end of the new cable until it is in the position shown in the illustration. Install the indicator, lens cover and cover in that order.

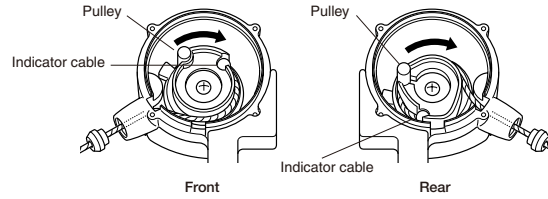

< At the Revoshift lever side >

Remove the cover fixing screws, and then remove the cover as shown in the illustration.

Turn the adjustment bolt to remove it, and then remove the cable from the Revoshift lever main unit.

Pull the end of the new cable until it is positioned in the pulley as shown in the illustration.

Check that the cable is securely in the groove at this time.

Tighten the adjustment bolt, install the cover and secure it with the screws.

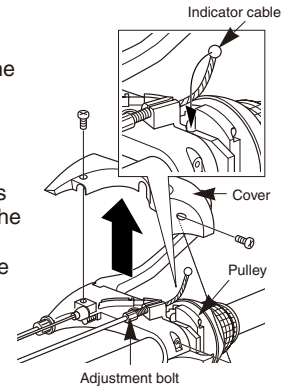

5. Making fine adjustments to the indicator cable

The indicator cable is equipped with an adjustment bolt. Turn the adjustment bolt to adjust to the optimum setting so that the needle points to "2" (at both front and rear).

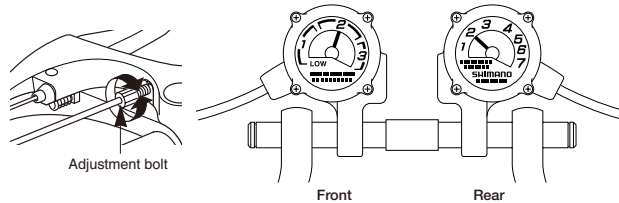

This service instruction explains how to use and maintain the Shimano bicycle parts which have been used on your new bicycle. For any questions regarding your bicycle or other matters which are not related to Shimano parts, please contact the place of purchase or the bicycle manufacturer.

SHIMANO®

SHIMANO AMERICAN CORPORATION
One Holland Irvine CA 92618 U.S.A. Phone 949-951-5003

SHIMANO EUROPA SHIMANO INC.
Industrieweg 24 NL-8071 CT Nunspeet Holland Phone 31-341-272222 77 Oimatsu-cho 3-cho Sakai Osaka 590-8577 Japan

Please note: specifications are subject to change for improvement without notice. (English)
© Feb. 2002 by Shimano Inc. XBC SZK Printed in Singapore

